



PELLENC S.A.

Quartier Notre Dame - Route de Cavailon
B.P. 47
84122 PERTUIS cedex
France
Tel : +33(0)4 90 09 47 00 Fax : +33(0)4 90 09 64 09
E-mail : pellenc.sa@pellenc.com
www.pellenc.com



Translation of the original
user guide

USER GUIDE

Vinion battery 150

optical trigger



Standalone VINION (with battery and cord)

CONTENT OF THE CARRY-CASE:

- 1- Pruning shears
- 2- A battery with its cord
- 3- A holster
- 4- A wrist strap
- 5- A sharpening stone
- 6- A flat-head screwdriver
- 7- The warranty card
- 8- A user guide



READ THE USER'S GUIDE CAREFULLY BEFORE USE



26_116772_C - 01/2016

Table of contents

INTRODUCTION	3
SAFETY INSTRUCTIONS	3
<i>GENERAL SAFETY INSTRUCTIONS FOR THE TOOL</i>	4
<i>SAFETY WARNINGS FOR BATTERY-POWERED SHEARS</i>	5
<i>SAFETY MEASURES ASSOCIATED WITH BATTERY USE</i>	6
<i>SAFETY MEASURES WHEN USING THE "PELLENC" CHARGER</i>	7
SAFETY SIGNALS	8
DESCRIPTION AND TECHNICAL CHARACTERISTICS	9
<i>DESCRIPTION OF PRUNER + ULIB 150 BATTERY COMBINATION</i>	9
<i>DESCRIPTION OF CUTTING HEAD</i>	10
<i>TECHNICAL CHARACTERISTICS OF THE PRUNING SHEARS</i>	10
<i>TECHNICAL CHARACTERISTICS - BATTERY</i>	11
FIRST-TIME OPERATION	11
<i>PUTTING THE PRUNING HOLSTER ON THE BELT</i>	12
<i>PUTTING THE LEAD AND WRIST STRAP IN PLACE</i>	14
<i>ADVICE FOR USERS</i>	15
USE	16
<i>USAGE MODES</i>	16
<i>OPTICAL TRIGGER</i>	17
<i>CHANGING MODE</i>	17
<i>"FUNCTIONAL" SETTING MODES</i>	18
<i>PARAMETER SETTING MODES</i>	19
<i>NOTES</i>	20
<i>SHARPENING</i>	20
<i>CHECK THE TIGHTNESS OF THE BLADE</i>	20
<i>CHANGING BLADE OR SHAFT</i>	21
MISC. MAINTENANCE	23
<i>WHEN NOT IN USE</i>	23
<i>INCIDENTS</i>	23
CHARGING THE BATTERY	24
THE DISPLAY SHOWING REMAINING BATTERY CAPACITY	25
BATTERY REPLACEMENT	25
WHEN NOT IN USE	25
INCIDENTS	26
<i>SUMMARY OF CHARGE INDICATOR AND BEEP MESSAGES</i>	26
«PELLENC SA» TERMS OF WARRANTY AND NON-RESPONSIBILITY CLAUSE	27
"EC" DECLARATION OF CONFORMITY	29

INTRODUCTION

Dear Customer,

Thank you for purchasing the *Vinion* pruning shears. Correctly used and maintained, this tool will give years of satisfactory performance.



ENVIRONMENTAL PROTECTION

Your equipment comprises numerous materials which can be valorised or recycled. Entrust these to your reseller or to an approved service centre so that they can be processed.



Comply with the regulations in force in your country as concerns environmental protection associated with your activity.

SAFETY INSTRUCTIONS



PLEASE SAVE THESE INSTRUCTIONS

This manual contains important information and operating instructions for the following tool: *Vinion* electronic pruning shears and battery model ULiB 150.

It is **ESSENTIAL** that you familiarise yourself **COMPLETELY** with this user guide.

Before use, read all instructions and warnings featured on the battery charger, the battery and the product using the battery.

Always comply with the instructions and illustrations in the manual.

- The "Pelenc tools" battery is a professional tool, for use only with compatible PELLENC tools.
- The PELLENC company accepts no responsibility for any damage caused by improper or unspecified use different from its original intention.
- The PELLENC company accepts no responsibility for any damage caused by the use of non-original parts or accessories.

All through this user guide you will find advisory notes and information entitled: **REMARK, CAUTION / WARNING**.

A **REMARK** provides additional information, clarifies a point or explains a step to be followed in detail.

The **CAUTION** and **WARNING** advisories are used to define a procedure which, if neglected or incorrectly performed, may lead to serious damage to the equipment and/or personal injury.

This advisory:  indicates that if the procedures or instructions are not complied with, any damage will not be covered by the warranty and the owner will be responsible for the repair costs.

Safety indications are also given on the tool; they remind you of the safety precautions to be taken. Identify and read these indications before using the tool. Immediately replace any indications that may become partially illegible or deteriorated.

Refer to the «SAFETY INDICATIONS» heading in order to identify the location of the safety indications on the tool.

No part of this manual may be reproduced without the written consent of PELLENC. The illustrations given in this manual are for information purposes and are in no way contractual. PELLENC reserves the right to make any modification or improvement to its products as deemed necessary without informing customers already in possession of a similar model. This manual forms an integral part of the tool and must accompany the tool if it changes hands.

SAFETY INSTRUCTIONS

GENERAL SAFETY INSTRUCTIONS FOR THE TOOL



CAUTION Read all the safety measures and all the instructions.
Retain all the safety measures and instructions for later reading.

This device is not intended for use by anyone (including children) with reduced physical, sensory or mental capabilities, nor by anyone lacking in experience or knowledge, except if they are supervised or have received prior instructions from a person responsible for their safety.

- The *Vinion* is a professional tool whose use is reserved exclusively for trimming vegetation.
- The PELLENC company accepts no responsibility for any damage caused by improper or unspecified use different from its original intention.
- The PELLENC company accepts no responsibility for any damage caused by the use of non-original parts or accessories.

WORK AREA SAFETY

- 1– Keep the work area clean and well lit.
- 2– Do not operate power tools in an explosive atmosphere, for example in the presence of flammable liquids, gases, or dust.
- 3– Keep children and bystanders away while operating the tool.

ELECTRICAL SAFETY

- 1– The power tool's connector must be adapted to the socket. Never modify the connector in any way whatsoever. Do not use adapter plugs with earthed (grounded) power tools.
- 2– Avoid body contact with earthed surfaces such as pipes, radiators, cookers, and refrigerators.
- 3– Do not expose tools to rain or damp conditions.
- 4– Do not misuse the power cord. Never use the cord for carrying, pulling or unplugging the power tool. Keep cord away from heat, oil, sharp edges, and moving parts.
- 5– Use an extension cord suitable for outdoor use when operating power tools outdoors.
- 6– If operating the power tool in a damp location is unavoidable, use a power supply protected by a residual current device (RCD).

PERSONNEL SAFETY

- 1– Stay alert, watch what you are doing, and use common sense when operating the tool. Do not use a power tool when you are tired or under the influence of drugs, alcohol, or medication.
- 2– Use safety equipment. Always wear eye protection.
- 3– Avoid accidental starting of the tool. Make sure the switch is in the off position before connecting the tool to the power source and/or battery pack, picking it up, or carrying it.
- 4– Remove any adjusting wrench before switching the tool on.
- 5– Do not rush. Maintain the correct position and balance at all times.
- 6– Dress appropriately. Do not wear loose clothing or jewellery.
- 7– Keep hair, clothing and gloves away from moving parts.
- 8– If devices are provided for connecting dust extraction and collection equipment, ensure that these are connected and properly used.

SAFETY INSTRUCTIONS

TOOL USAGE AND MAINTENANCE

- 1– Do not force the tool. Use the tool suited for the job.
- 2– Do not use the tool if the switch does not allow it to be switched on and off.
- 3– Disconnect the connector from the power source and/or battery pack prior to any adjustment, change of accessories, or before putting the tool away.
- 4– When not in use, keep tools out of the reach of children and do not allow persons unfamiliar with the power tool or these instructions to operate it.
- 5– Comply with the tool servicing instructions. Check that the moving parts are not out of alignment or jammed, that there are no broken parts or that there is no other condition which could affect the operation of the tool. If damaged, have the tool repaired before using it.
- 6– Keep the cutting components sharp and clean.
- 7– Use the tool, accessories and blades, etc. in accordance with these instructions, taking into account the working conditions and the work to be done.

MAINTENANCE AND UPKEEP

- 1– Have the tool serviced by an authorised PELLENC distributor, using only guaranteed original spare parts.

SAFETY WARNINGS FOR BATTERY-POWERED SHEARS

- 1– Never modify the connector in any way whatsoever.
- 2– THIS TOOL MAY CAUSE SEVERE INJURIES. Read carefully the instructions relative to the proper handling, operation, maintenance, start-up and stop of the tool. Familiarize with all its controls and proper use.
- 3– When the pruning shears are not in use, systematically turn the battery to the off position "0".
- 4– Before starting the motor, make sure that the blade is not in contact with any object.
- 5– Always use a suitable lifting device complying with the working regulations in force for overhead works.
- 6– Never use the tool if it is damaged, incorrectly set or incompletely assembled.
- 7– Never remove or disable a safety device. Have the safety device repaired if is faulty.
- 8– Never disconnect the pruning shears power cord without first checking that the ON/OFF switch of the battery has been put in the OFF position "0".
- 9– Never carry the pruning shears suspended from the power cord.
- 10– Do not disassemble the pruning shears.
- 11– Do not open the direct box.
- 12– Do not try to cut too large pieces of wood or other materials than wood.

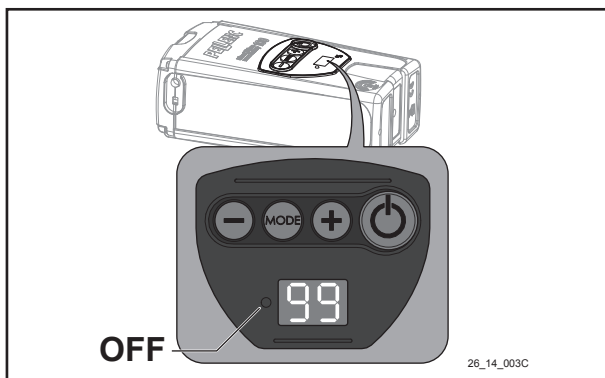

• Figure 1: Battery off (LED off)

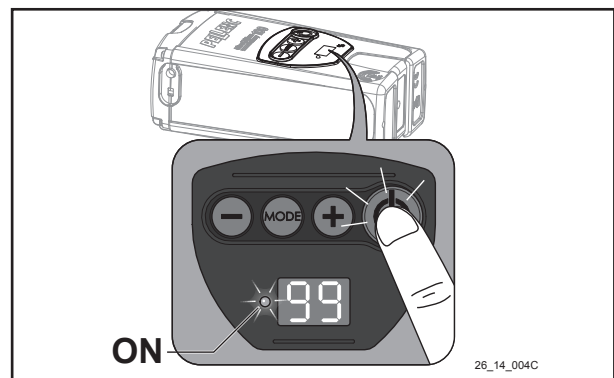

• Figure 2: Battery on (red LED on)

SAFETY INSTRUCTIONS

SAFETY MEASURES ASSOCIATED WITH BATTERY USE

- 1– If not using the battery unit, store it away from other metal objects such as paper clips, coins, keys, nails, screws or other such small metal items that might form a connection between the two terminals. Creating a short-circuit between the battery terminals can lead to burns or cause a fire.
- 2– Keep the battery out of the reach of children and place it on a non-combustible support.
- 3– Do not interfere with its cooling cycle.
- 4– Do not use or leave the battery near a heat source ($> 60^{\circ}\text{C}$).
- 5– Do not leave the battery in direct, strong sunlight.
- 6– Do not expose the battery to microwaves or high pressure.
- 7– Do not immerse the battery in water.
- 8– The batteries must be charged in a dry, ventilated room at a temperature between 10°C and 25°C maximum, away from any moisture.
- 9– If the battery is not used for 10 days, it discharges automatically to prepare for storage. During this phase it will become warm.
- 10– If the battery is not used for 10 days, the battery will automatically discharge until it reaches its storage charge rate, and then goes to sleep. It will heat up during this phase.
- 11– The battery may lose 1 to 4 % of its capacity when exposed to a temperature higher than or equal to 55°C for one week.
- 12– The charging location must be equipped with a class D fire extinguisher (for metal fire) in good working order.
- 13– The standards in effect must be complied with when either shipping a complete tool or a battery. A battery is a product that is classified as UN3480 Class 9 when transported alone, and UN3481 Class 9 when it is transported with the tool.
- 14– Use of a battery other than that provided by Pellenc SA is dangerous (risk of serious injury). If a different battery is used, Pellenc SA cannot be held responsible for any consequences.
- 15– The battery must be protected from any impact and must be positioned and secured appropriately during transportation.
- 16– In the case of suspicious smoke, place the battery outside the charging area or transportation vehicle as far away as possible from any inflammable material.
- 17– Never store a battery when its capacity is below 50 %. Recharge it before storage if the value is below 50 %.
- 18– In inappropriate conditions, a liquid can flow batteries; avoid contact with it. In the event of accidental contact, rinse with water. In the event of contact with eyes, seek professional medical help. The liquid leaking from the batteries can cause irritations or burns.
- 19– Pellenc power tools must only be used with the battery units designed for the purpose. Use of other battery units can present a risk of injury and fire.
- 20– Only recharge using the "Pellenc" charger indicated by the manufacturer. A charger adapted to one type of battery unit may present a fire risk if used with a different battery unit.
- 21– Do not use the battery for any purpose other than that initially envisaged (exclusively for use with Pellenc tools).
- 22– At the end of its life, the battery must be returned to the authorized distributor from whom it was purchased to be recycled in accordance with waste regulations.
- 23– Fragile case, contains an electronic board and lithium.

SAFETY INSTRUCTIONS

SAFETY MEASURES WHEN USING THE "PELLENC" CHARGER

- 1**–During operation, the charger temperature can reach 60° C. There must be no flammable material within 1.5 meters of the charger and the battery.
- 2**–Place the charger out of children's reach and onto a non-combustible support.
- 3**–Do not interfere with its cooling cycle.
- 4**–The charger delivered with the is intended for charging it. Do not charge non-rechargeable batteries.
- 5**–The charging location must be equipped with a class D fire extinguisher (for metal fire) in good working order.
- 6**–If the output cord is cut or damaged, bring the entire charger back to the authorised distributor where the tool was purchased.
- 7**–Only recharge using the "PELLENC" charger indicated by the manufacturer. A charger adapted to one type of battery unit may present a fire risk if used with a different battery unit.
- 8**–This charger is designed to charge the batteries of Pellenc's lithium tools.
- 9**–Do not use it for any other purposes.
- 10**–Children must be supervised to ensure they do not play with the charger.
- 11**–Verify that the cable cannot be folded and does not touch hot surfaces or sharp edges.
- 12**–Ensure good ventilation during the charge.
- 13**–Never cover the charger.
- 14**–This charger must not be used outdoors.
- 15**–Make sure the power connector is not exposed to water.
- 16**–Never charge a damaged battery.
- 17**–Grid connection must comply with national electrical regulations (EN60204-1).
- 18**–Check the cable of the charger before using it. Never use the charger if the cable is damaged
- 19**–When the battery is charging, place the charger on a non-flammable support, more than 1.5 m away from any flammable object.

SAFETY SIGNALS

Do not expose to rain.



Read the user guide.



This equipment must be used at a temperature of between -5° and +35°C.



Lithium-ion battery.

At the end of its life, the battery must be returned to the authorized distributor from whom it was purchased to be recycled in accordance with waste regulations.

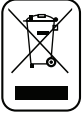

Equipment compliant with EC standards.



The charger supplied with the tool is exclusively designed to recharge the lithium-ion battery.

A utiliser uniquement
avec le chargeur de
batterie PELLENC
modèle CB5004 HV

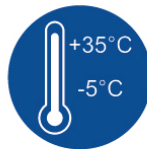

BATTERY
43.2V \approx 3.45Ah
150Wh

REFERENCE
112315

IEC/EN 61960
43.2V \approx 3.3 Ah
12INR19/66

A utiliser uniquement avec le chargeur de batterie PELLENC modèle CB5004HV
Usar sólo con el cargador de batería PELLENC del modelo CB5004HV
For use only with PELLENC's battery charger model CB5004HV
Nur zur Verwendung mit dem Ladegerät Modell PELLENC CB5004HV
So usar com o carregador de bateria PELLENC CB5004HV
Per l'utilizzo solo con il caricabatteria modello PELLENC CB5004HV

DESCRIPTION AND TECHNICAL CHARACTERISTICS

DESCRIPTION OF PRUNER + ULIB 150 BATTERY COMBINATION



26_14_002C

- 1– Pruner lead
- 2– Pruner connector plug
- 3– Pruning shears
- 4– Trigger
- 5– Elastic wrist strap
- 6– Wrist strap clip
- 7– Adjustable belt
- 8– Holster

- 9– Belt clip
- 10– 150 battery
- 11– Mode change button
- 12– ON/OFF BUTTON
- 13– Battery level display
- 14– ON/OFF LED
- 15– Grinding stone
- 16– Grinding stone holder

DESCRIPTION OF CUTTING HEAD

- 1– Trigger
- 2– Blade shaft
- 3– VINION blade
- 4– VINION hook
- 5– Knurled adjustment washer
- 6– Locking blade
- 7– CHC M6 screw
- 8– Lockwasher
- 9– Clamping wheel
- 10– Guard
- 11– Rod clevis

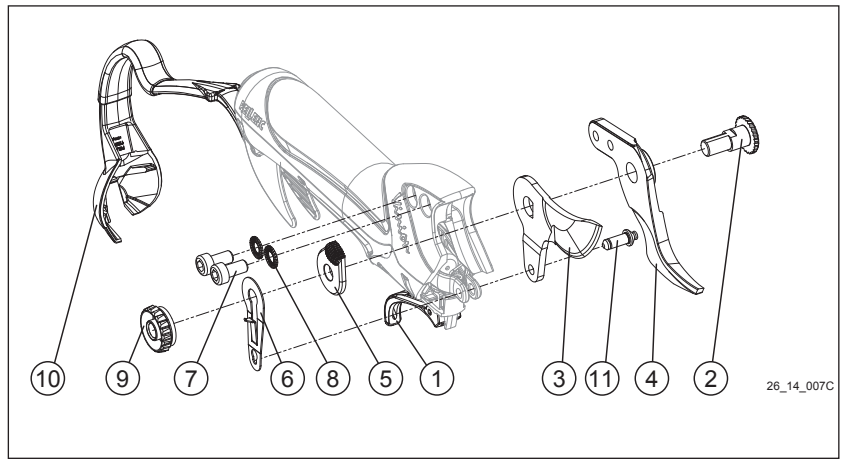

- 1– Trigger
- 2– Optical sensor
- 3– Tool indicator

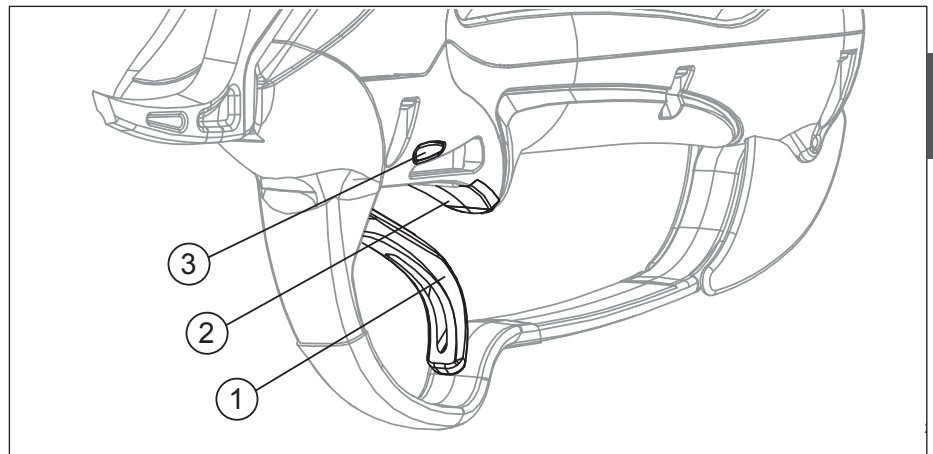

TECHNICAL CHARACTERISTICS

TECHNICAL CHARACTERISTICS OF THE PRUNING SHEARS

	Vinion
Cutting capacity	up to 35 mm, depending on type of wood
Pruning shears power supply voltage	43.2 V
Average power	180 W
Battery life	Depending on the use and type of battery
Weight of pruning shears	670 g

Total vibration values (triax vector sum) determined in accordance with EN 60745. (Uncertainty $K=1.5 \text{ m/s}^2$)	$a_h < 2.5 \text{ m/s}^2 \text{ max.}$
--	--

Noise value measured according to the standard EN 60745-1	
Sound power level measured (uncertainty of $K=3 \text{ dB}$)	$L_{WA} = 81 \text{ dB maximum}$
Level of acoustic pressure at the work station measured (uncertainty of $K=3 \text{ dB}$)	$L_{WA} = 70 \text{ dB maximum}$

TECHNICAL CHARACTERISTICS

TECHNICAL CHARACTERISTICS - BATTERY

Name	Ulib 150
Nominal battery voltage	43.2 V ===
Type of battery	12 cells in 1 pack
Battery capacity	3.45 Ah
Battery power	864 W
Battery energy	150 Wh
Battery life	According to the use
Weight of the battery unit	845 grams (without cord)

FIRST-TIME OPERATION

Before using the battery for the first time, it must be fully charged (99% steady).
(See battery charging section, page 24)

- 1- Remove pruning shears, battery and belt from the packaging.
- 2- Check that the battery is turned off (see Figure 1 on page 5)



Given the machining precision of the pruning shears' components, for optimum performance, a 2-3 day-long trial period is practical and allows you to benefit from a reduction in consumption and noise.

PUTTING THE PRUNING HOLSTER ON THE BELT

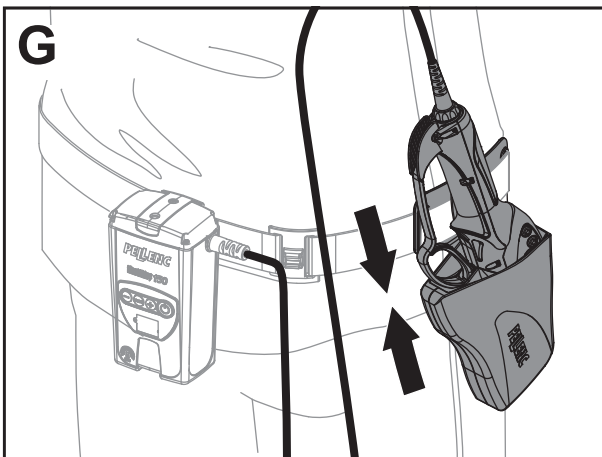
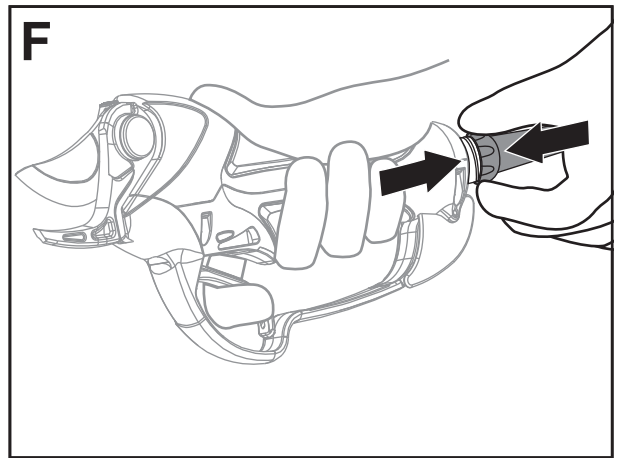
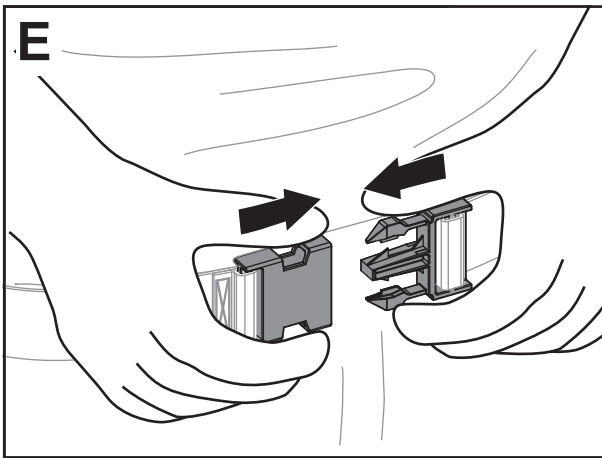
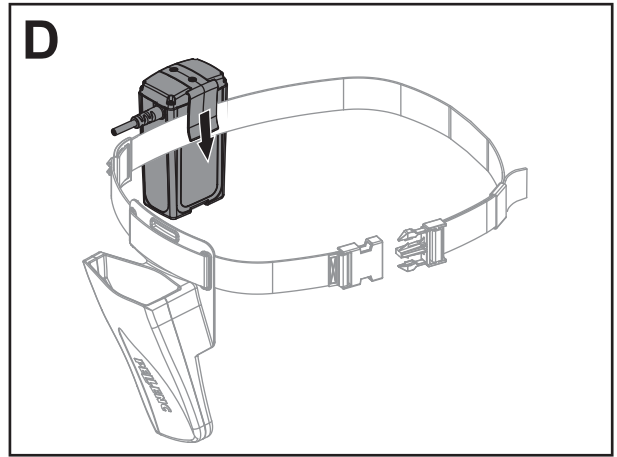
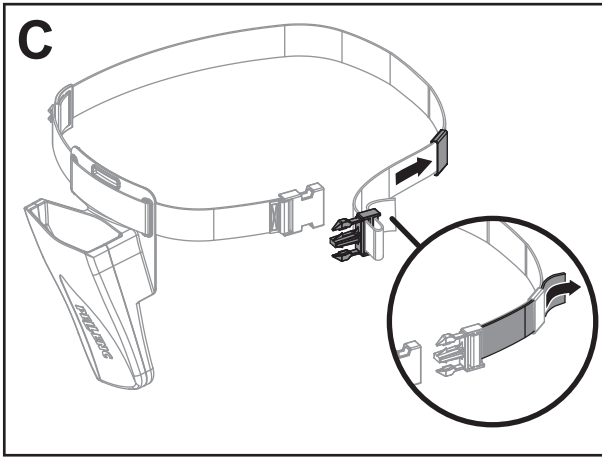
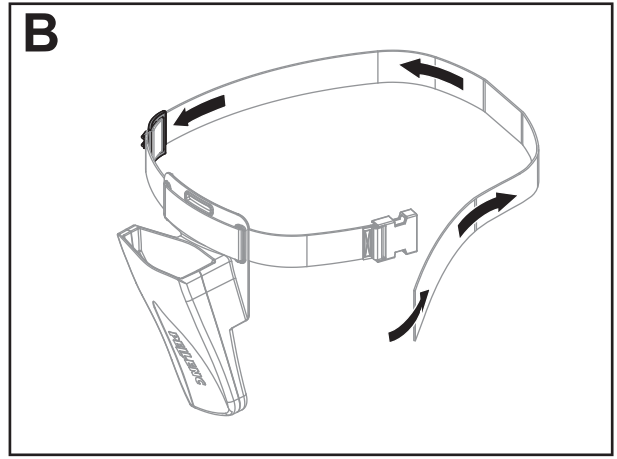
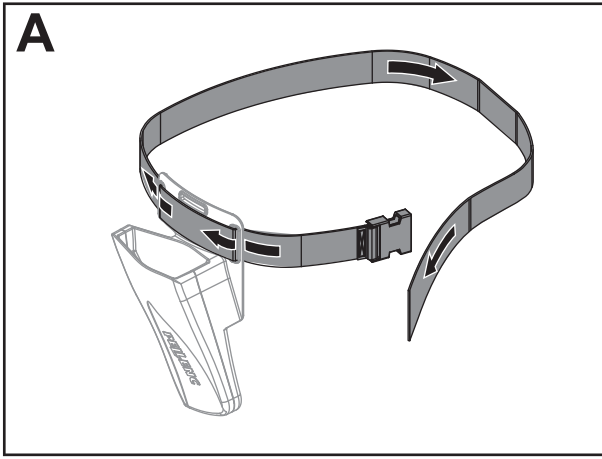

PUTTING THE PRUNING HOLSTER AROUND THE THIGH

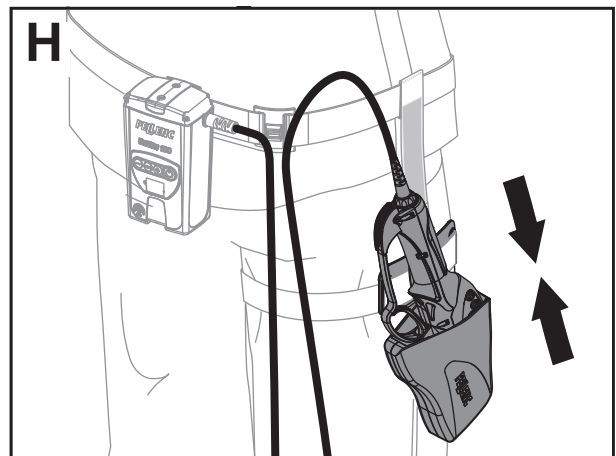
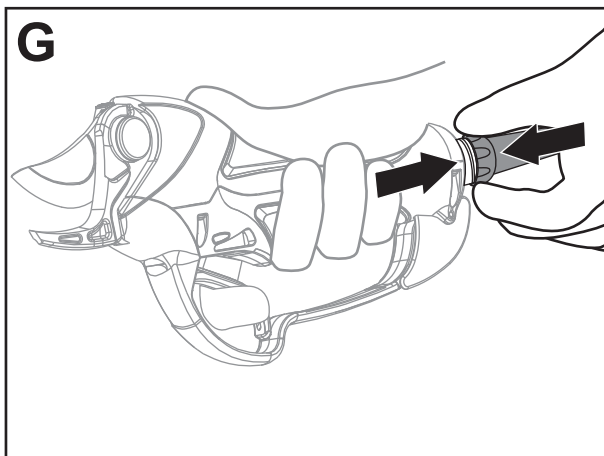
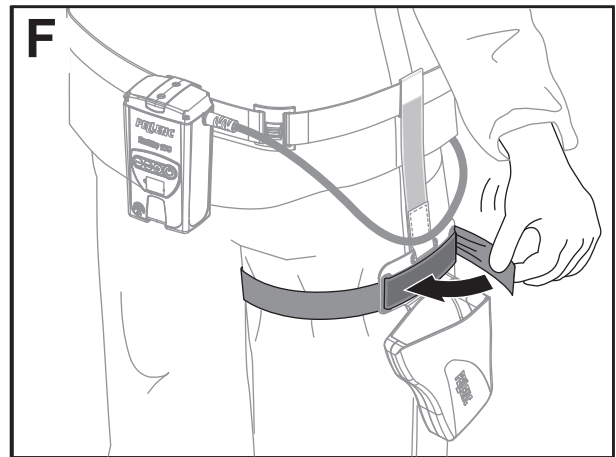
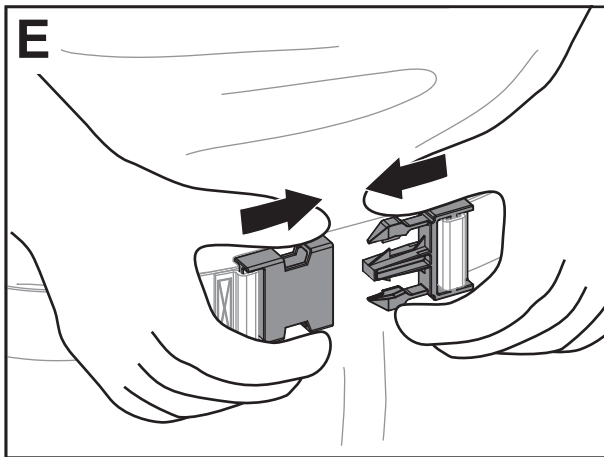
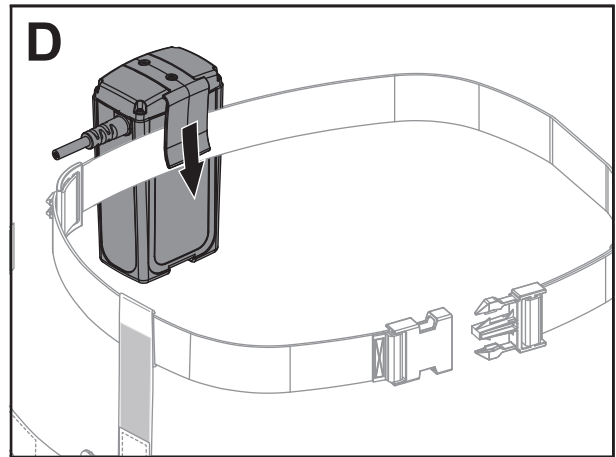
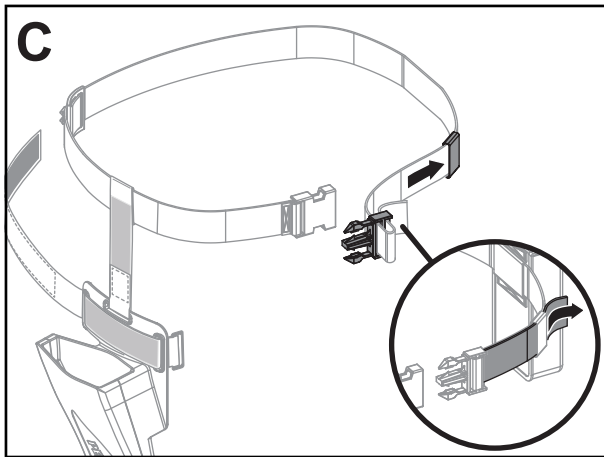
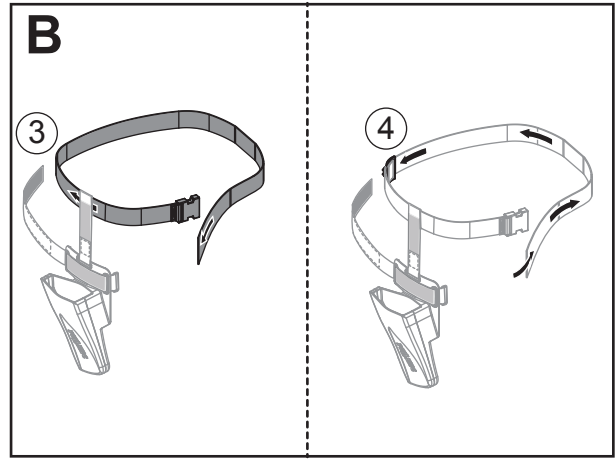
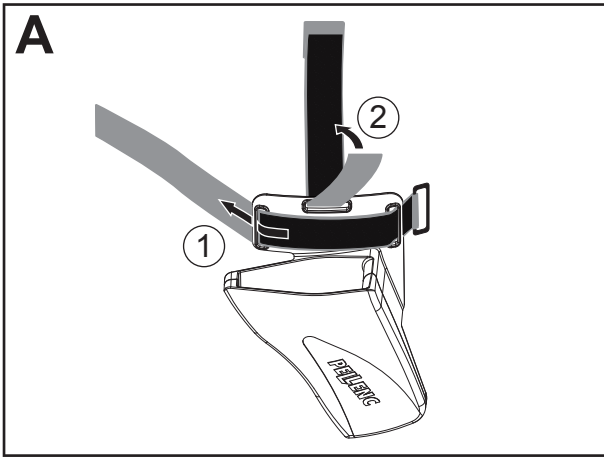

PUTTING THE LEAD AND WRIST STRAP IN PLACE

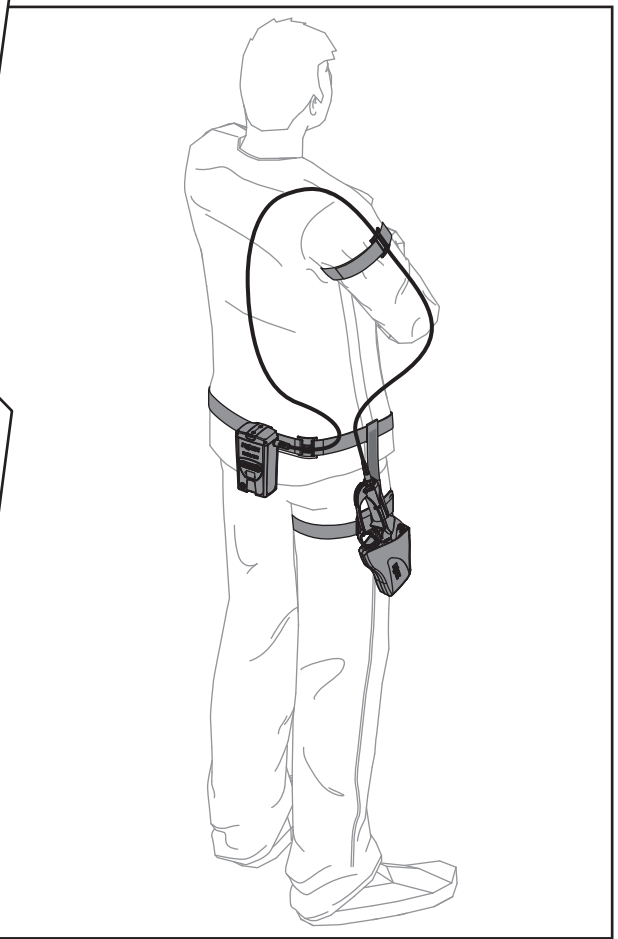
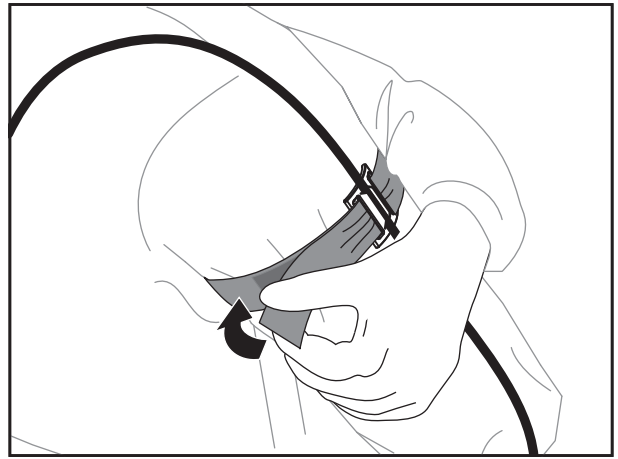
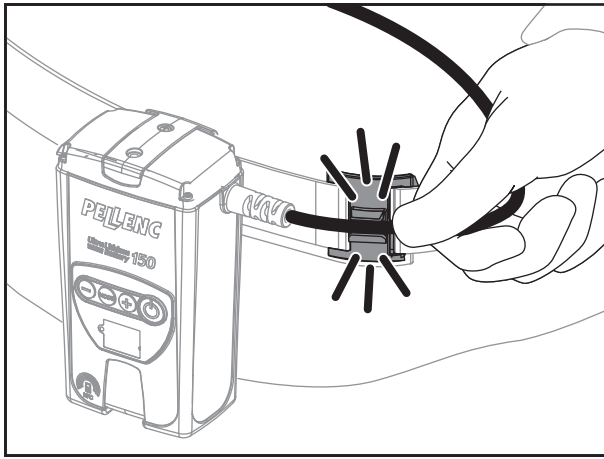

USE

- Press ON/OFF button for 1 s to turn on the battery (see figure 2, page 5), the red LED lights up then the battery beeps 3 times. The pruner is ready for use, press the bottom trigger, then release it, the blade opens (the opening and closing of the blade are proportional to the movement of the finger).
- To stop your pruning shears, close the blade, using the trigger, and keeping it closed, press on the switch. The battery beeps once and the red LED goes off.
- The pruning shears stop closing if the cut required is too hard. They can then only open.
- To put the pruning shears in "standby" mode, press the trigger and hold it closed for about 4 seconds.
- To quit standby mode, press the trigger again and the blade opens.
- If the trigger is not operated for one minute, the tool automatically goes to standby; press the trigger again to leave standby mode.

ADVICE FOR USERS

- You must take all necessary care to prevent catching the lead of the pruning shears in the branches. To do this, attach the lead to your arm using the wrist strap provided. (see page 14)
- The operating time and service life of the pruning shears mainly depend keeping the blade properly sharpened and adjusted.
- It is essential to remove the burrs (wire edge) from the cutting edge of the blade, and to file it off within the first 15 minutes of use.
- We recommend that you do not disconnect the lead of the pruning shears from the battery unit after use each day, but wind it around the "battery" unit and replace them both in their carry-case.



The PELLENC battery may be put into the user's pocket or worn on the belt.

USE

There are various usage modes available to best meet working needs and to save battery power. The "Pruning shears + Battery" combination is supplied in the most efficient mode: Mode U1

USAGE MODES

DESCRIPTION OF OPERATING TYPES AVAILABLE

Mode U1 PERFORMANCE (factory mode)

- Gradual, fast operation, with half-opening
- The pruning shears LED is green when operating.
- The pruning shears LED flashes green on standby.

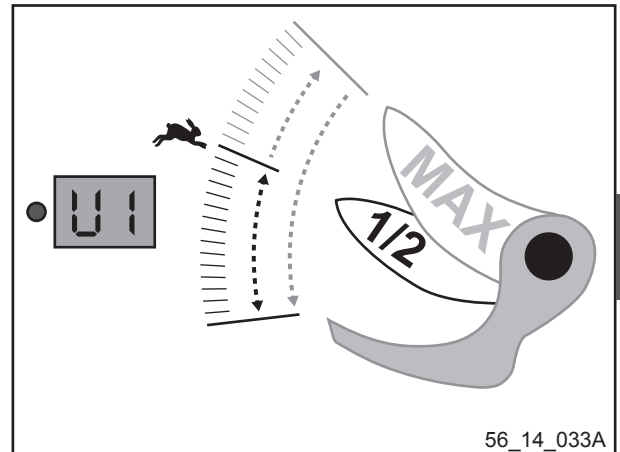

Mode U2. ECONOMY AND COMFORT

- Gradual, smooth operation, with half-opening
- The pruning shears LED flashes alternately green and red in operation.
- The pruning shears LED flashes alternately green and red faster when on standby.

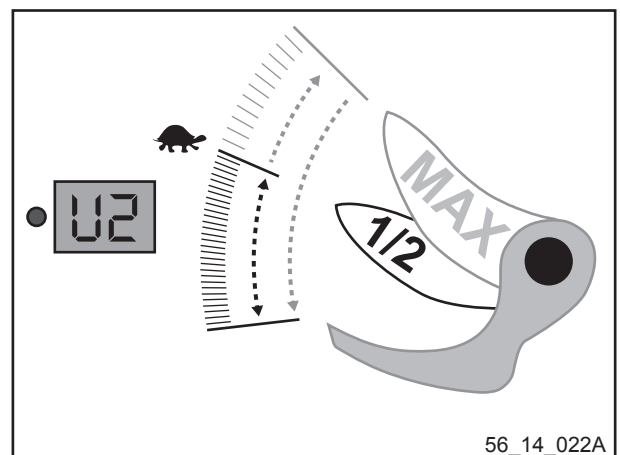

- Mode U3.ALL OR NOTHING
- Fast operation "all or nothing" with half-opening
- The pruning shears LED is red when operating.
- The pruning shears LED flashes red on standby.

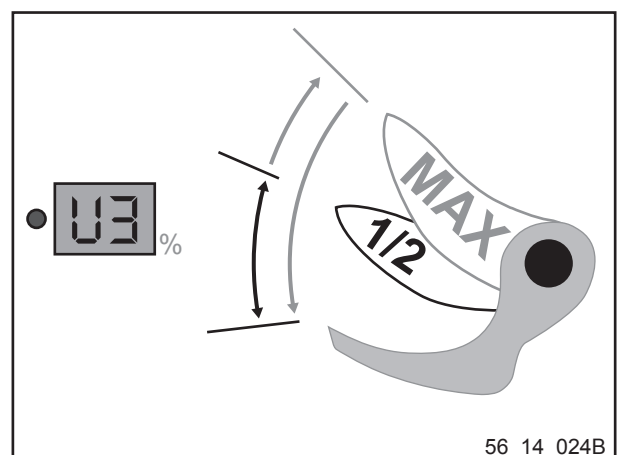

Removing your finger from the trigger opens the blades wide, no matter which function is chosen.



The fully proportional system (consumes more energy) can be implemented by your dealer free of charge.

OPTICAL TRIGGER

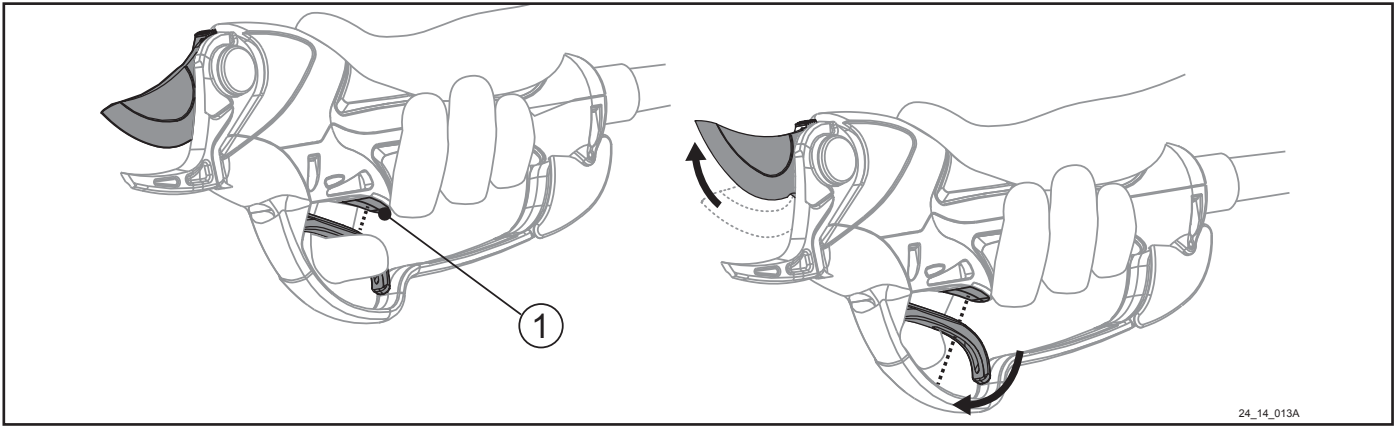

The blade stays half-open as long as the optical system (1) detects your finger on the trigger. When your finger releases the trigger, the optical system tells the blade to open fully.

This option helps when cutting small wood, thus saving energy. After a few minutes' use, this optical system becomes an essential feature of your daily work.



The kind of gloves worn can have an effect on the way the optical trigger works. We recommend not wearing black gloves.



If the optical trigger stops working properly, check that there is nothing obstructing the slot in the trigger or clean the window of the optical sensor with rubbing alcohol.

CHANGING MODE

U1 / U2 / U3 MODES

- 1- Turn the battery on, with the tool connected
- 2- Press the "mode" button
- 3- Choose modes U1, U2 or U3 by pressing + or -.
- 4- Press the "mode" button to validate.

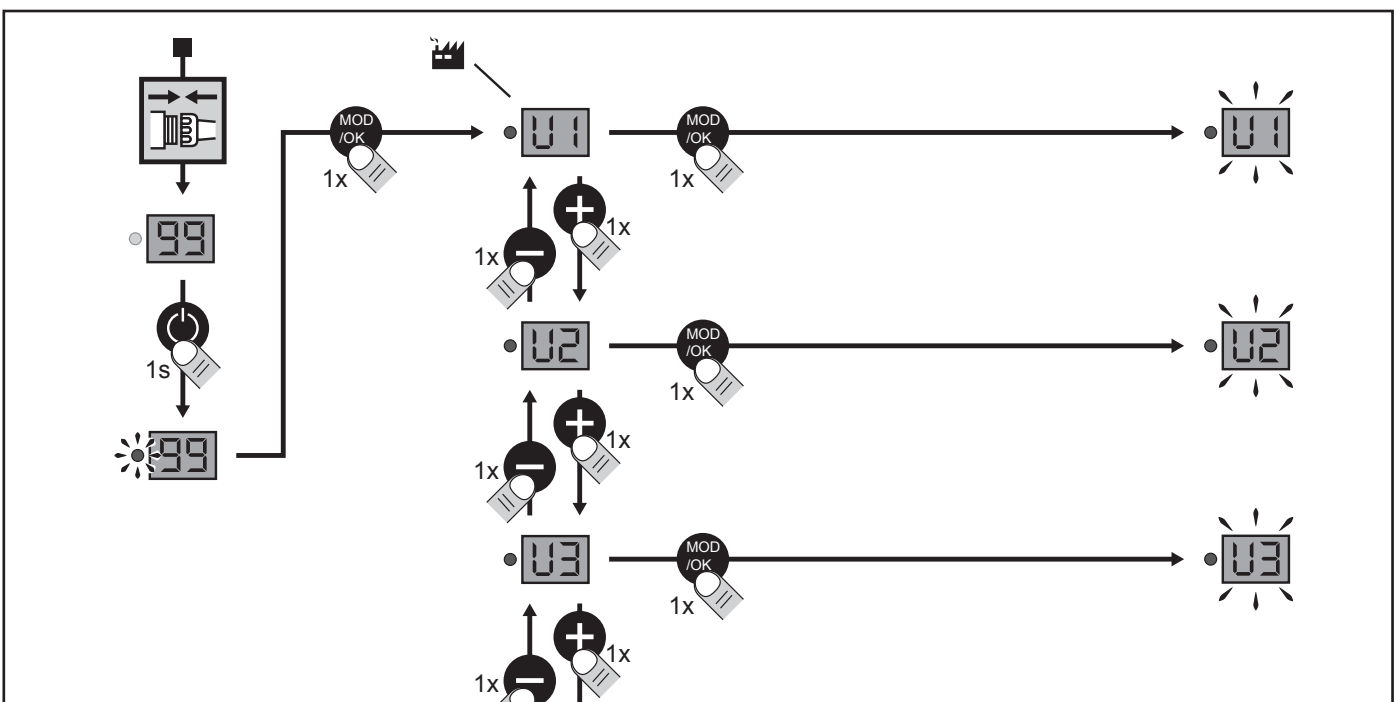

"FUNCTIONAL" SETTING MODES

F5 MODE: BLADE CROSSING ADJUSTMENT

- 1– Turn the battery on, with the tool connected
- 2– Press the "mode" button
- 3– Select function F5, by pressing + or -.
- 4– Press the "mode" button to validate.
- 5– Press + or - to adjust the blade crossing
- 6– Press the "mode" button to validate.

Adjustment range:

- 9 = maximum value
- 1 = minimum value
- Factory setting = 5

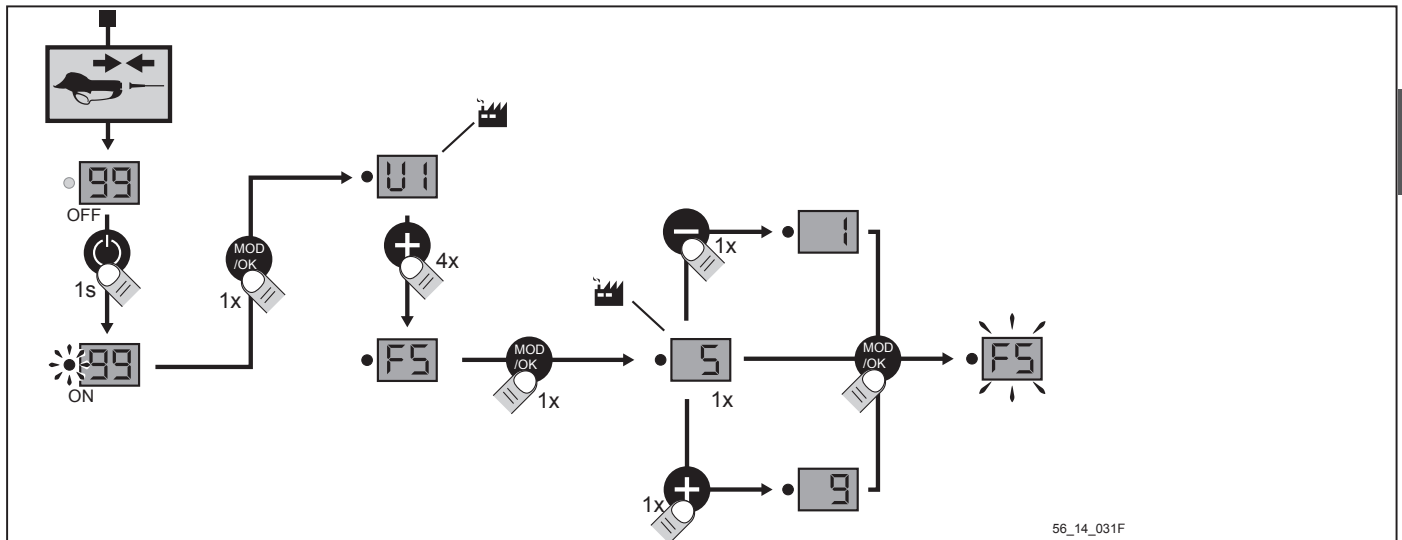

F6 MODE: HALF-OPENING SETTING

- 1– Turn the battery on, with the tool connected
- 2– Press the "mode" button
- 3– Select function F6, by pressing + or -.
- 4– Press the "mode" button to validate.
- 5– Press + or - to adjust the half-opening of the blade
- 6– Press the "mode" button to validate.

Adjustment range:

- 9 = maximum value
- 1 = minimum value
- Factory setting = 4

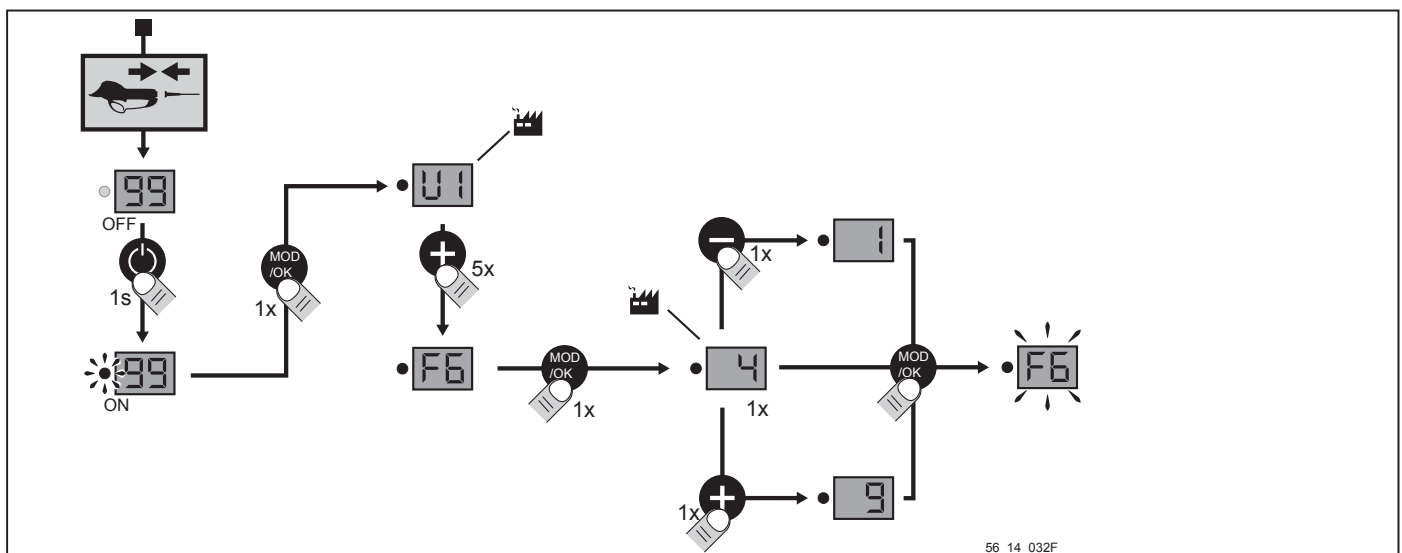

PARAMETER SETTING MODES

• You can set the parameters for the tool's adjustment level to make it easier to use.

L1: **"Display"** Mode: The tool can only be used in the preset configuration.

L2: **"Normal"** mode: The user has access to 3 operating modes, U1 to U3, but these cannot be adjusted.

L3: **"Expert"** mode (default): The user has access to 3 operating modes U1 to U3 and two settings (blade crossing = F5 and half opening = F6).

PARAMETER SETTING

The tool's parameter setting modes can be altered as follows:



DISCONNECT THE PRUNING SHEARS AND TURN ON THE BATTERY

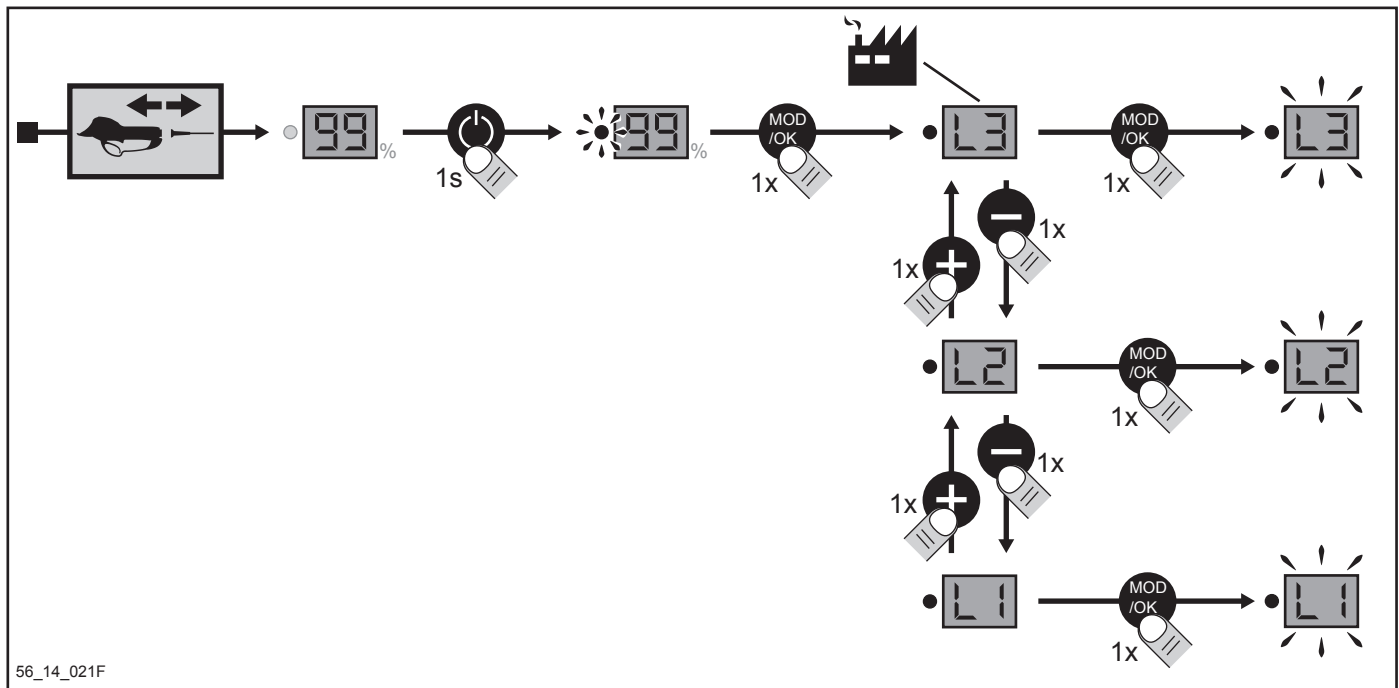

AFTER CONFIGURING THE USAGE MODE ALLOWED FOR THE USER, TURN THE BATTERY OFF, THEN RECONNECT THE TOOL.



IF YOU NEED TO CHANGE MODES, SIMPLY REPEAT THE ABOVE OPERATION.

NOTES

- It takes a few hours cutting to become familiar with the pruning shears.
- If cutting is no longer sharp and effortless, this means that it is using more energy than necessary. Check the sharpening, the tightening of the blade and the general condition of the pruning shears.

SHARPENING

This is important because it determines the quality of the cut and the durability of blades, the mechanical parts and the battery life. Its frequency depends of course of the wood cut (hardness and diameter), the pruning pace and sharpness of the blades (a special grinding stone was supplied to you). Therefore, during the first days of use, it is necessary to frequently check the condition of the cutting blade to maintain its edge by refreshing the cutting line a bit and often (a quick look every fifteen minutes will quickly give you an idea of this frequency).

IT IS IMPERATIVE TO REMOVE THE BURR FROM THE CUTTING EDGE OF THE BLADE AND RESHARPEN A FIRST TIME AFTER THE FIRST 15 MINUTES.

CHECK THE TIGHTNESS OF THE BLADE

- 1– Blade shaft
- 2– Blade
- 3– Hook
- 4– Knurled adjustment washer
- 5– Clamping wheel
- 6– Pawl of the locking blade

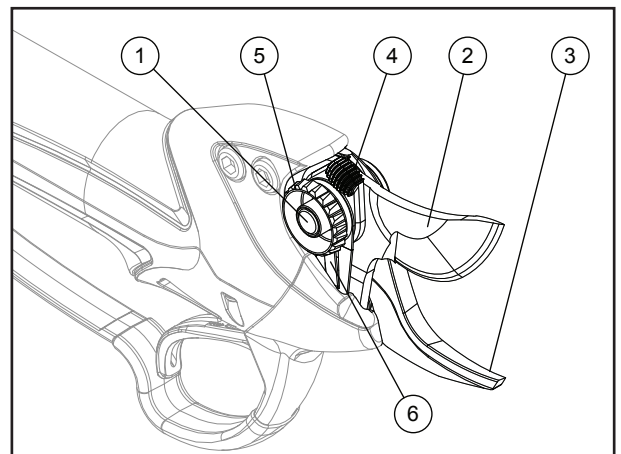

- There must be no lateral play.
 - The play in the cutting direction must be detectable by hand.
- For this:
- Carry out these operations with the blade open and battery turned off. (see figure 1 page 5)
 - Tighten the adjustment wheel (5) until the knurled adjustment washer no longer turns.
 - Loosen the wheel (5) a quarter turn.
 - Check tightening of the blade:
 - The knurled washer (4) must be able to rotate with the blade open.
 - The knurled washer (4) must not turn with the blade closed.
 - Manually readjust tightening if needed using the wheel (5).
 - By turning the wheel (5) in the clockwise direction to tighten.
 - By pressing the pawl (6) and rotating the wheel (5) counter-clockwise to loosen.
 - Over-tightening may cause incorrect operation, poor cutting at the blade tip, and significant reduction in battery life.

CHANGING BLADE OR SHAFT

Follow the instructions in the order given:

- 1- Open the blade fully.
- 2- Turn off the battery.
- 3- Disconnect the pruning shears lead.
- 4- Open the guard as shown below.

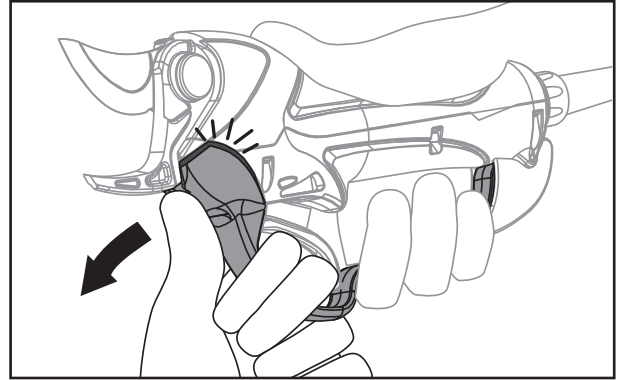
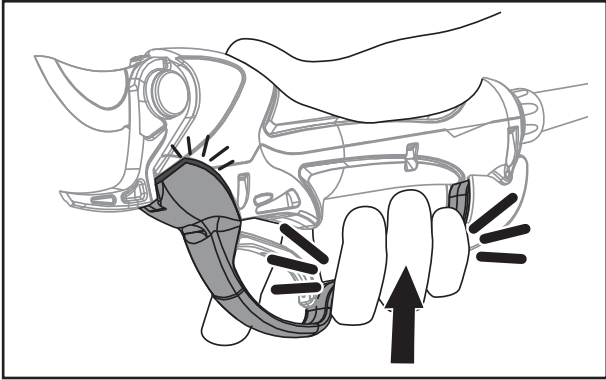

- 5- Unscrew and remove the wheel.

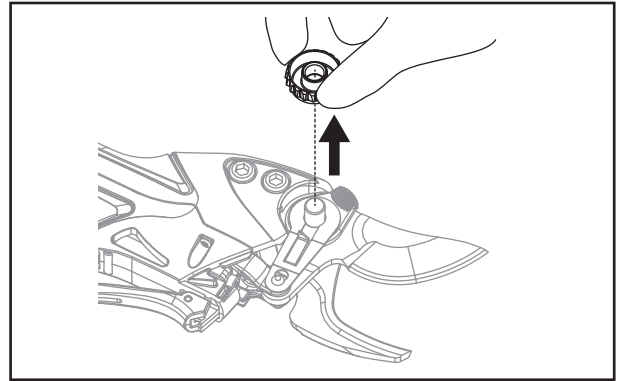
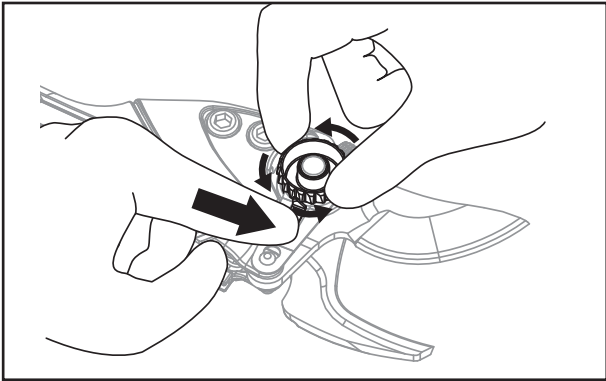

- 6- Remove the blade shaft

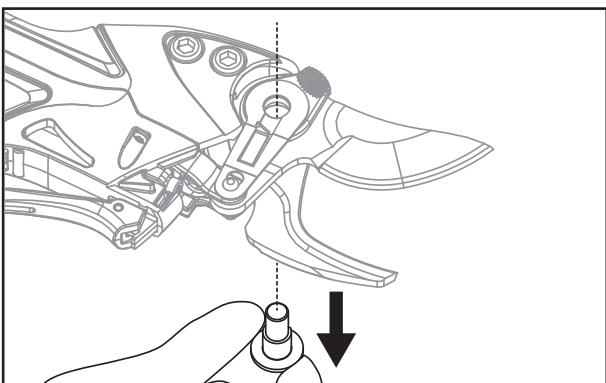

- 7- the locking blade.

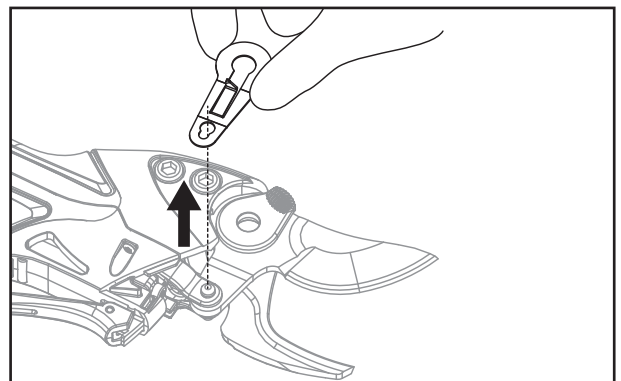
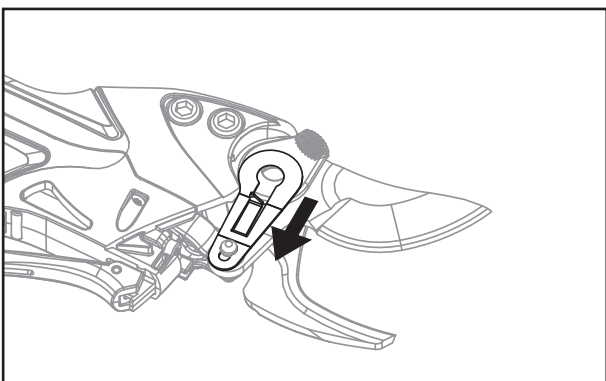

CHANGING BLADE OR SHAFT

1– Remove the adjustment washer

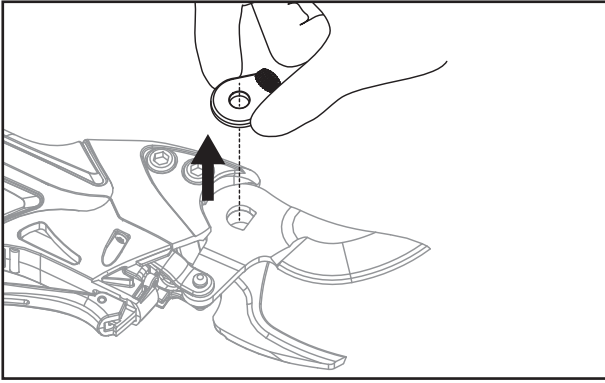

2– Remove the clevis pin and replace worn parts.

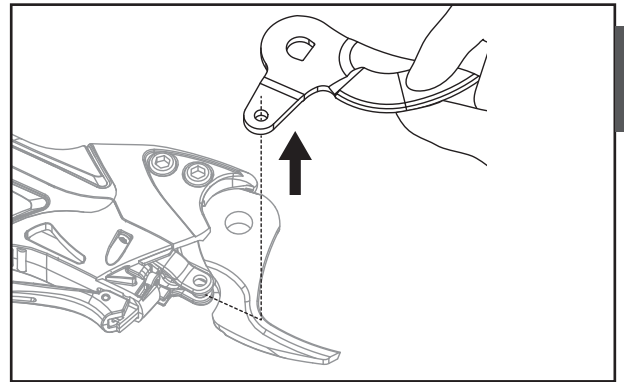
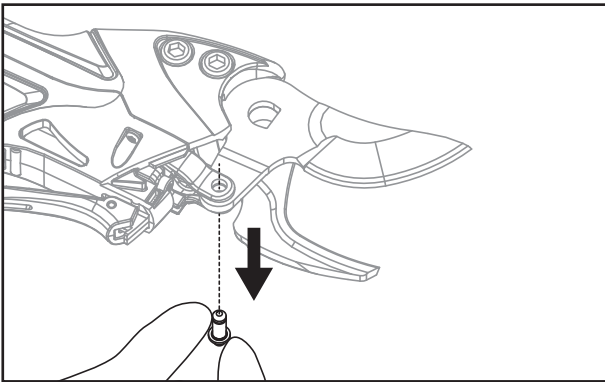

3– Replace the blade on the hook after greasing the seating, then replace the blade shaft and the clevis pin.

4– Replace the adjustment washer and locking blade.

5– Tighten the wheel on the blade shaft.

6– Clip the guard in place again by pressing on its centre.

7– Tighten the blade shaft, as instructed in the previous section.

8– Reconnect the pruning shears.



ATTENTION: Never operate the pruning shears without the blade and shafts, as this will cause damage to the ball screw and the body of the shears.

MISC. MAINTENANCE

Avoid the formation of abrasive paste (oil + soil) as much as possible via frequent cleaning. To do this:

- Clean the front of the shears with a cloth and compressed air, do not use solvents such as trichlorethylene, turpentine, gasoline, or similar products.
- Lubricate the blade and the blade axes sparingly but often (once a week).
- Do not leave the pruning shears in the soil or exposed to the elements.

EVERY 200 HOURS, CHANGE THE FOLLOWING KITS:

- VINION blade kit (ref. 118259)
 - VINION blade shaft kit (ref. 122671)
 - VINION maintenance kit (ref. 122672)
- Refer to your dealer before changing this kit.

WHEN NOT IN USE

- Store the pruning shears, battery unit and charger in their carry-case, away from heat, dust and damp, and check the battery is properly turned off.
- Never store the battery at an ambient temperature of more than +45 °C.
- **In order to conserve a long battery life and prevent deterioration, the battery must be charged when stored and recharged every 24 months if it is not used.**
- Never operate the switch while the shears are in storage.
- In the OFF-SEASON, you may have your pruning shears overhauled by an approved repairer. For more information, consult your repairer or contact us.
- Storage of the battery must be done in a cool, dry place with a temperate between 0° C and + 25° C. No combustible objects should be placed within 1.5 meters of the battery.

INCIDENTS

If the shears no longer work:

1– Turn off the battery.

2– Check the battery is charged, as shown on the gauge. If it shows 00, recharge it with the charger supplied.

3– Check the lead is connected and the thumb-wheel tightened.

4– If the shears do not work, return the complete equipment in its original packaging to a certified repair service.

NEVER ATTEMPT TO OPEN ONE OF THE ELEMENTS (PRUNING SHEAR, BATTERY) OTHER THAN THOSE AUTHORISED IN THIS NOTICE (YOU RISK DAMAGING THEM AND MOST IMPORTANTLY, YOU VOID THE WARRANTY).

CHARGING THE BATTERY

When the battery is discharged, the tool stops automatically.

The gauge display is off and the buzzer beeps (see "MESSAGES TABLE" page 26).

A. Press the on/off button (6) at once.

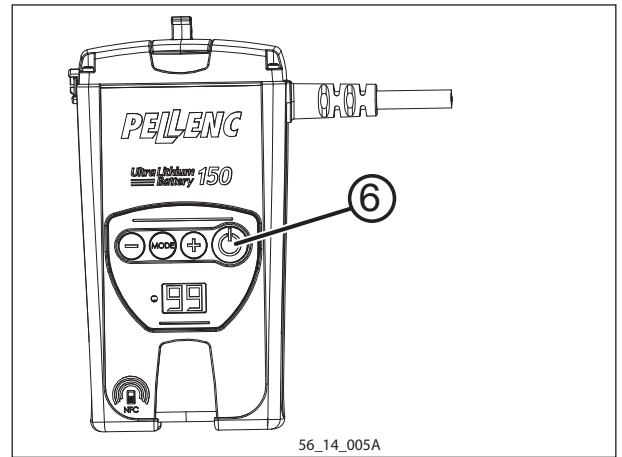

Before using the battery for the first time at the start of a new season, it must be fully charged (99% steady).

B. Place the charger and battery in a dry, ventilated and dust-free room at 10-25°C. Place the battery lying in a horizontal position.



ATTENTION:

Before connecting the charger to the power outlet, check that the power system characteristics comply with the specifications given on the charger (see "Specifications" on page 8).

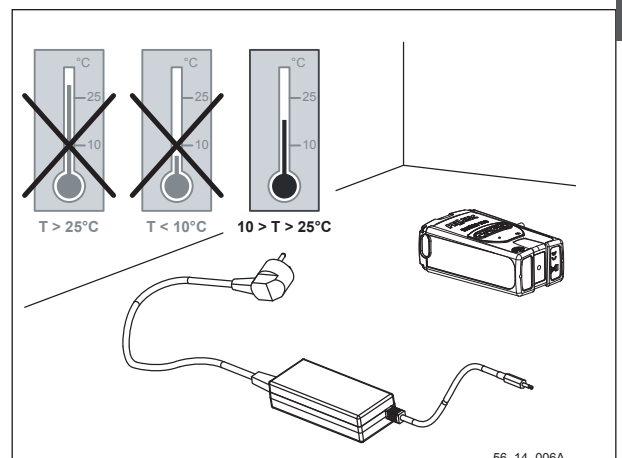

C. Connect the charger power connector (1) to the power outlet. The charger LED lights up red.

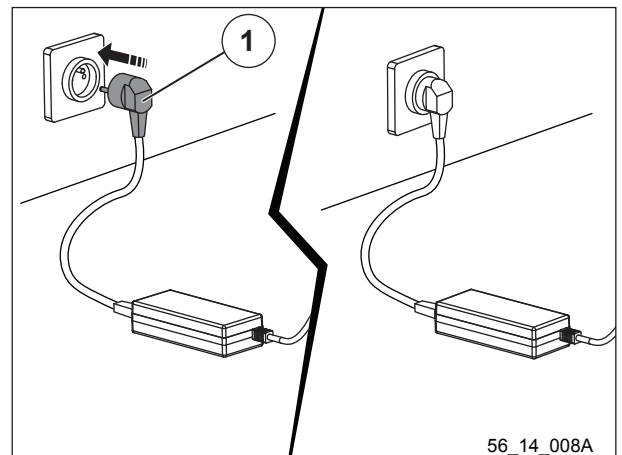

D. Connect the charging cord (2) to the battery's charging connector (3). The charger indicator (4) flashes green, and the battery indicator (5) flashes orange.

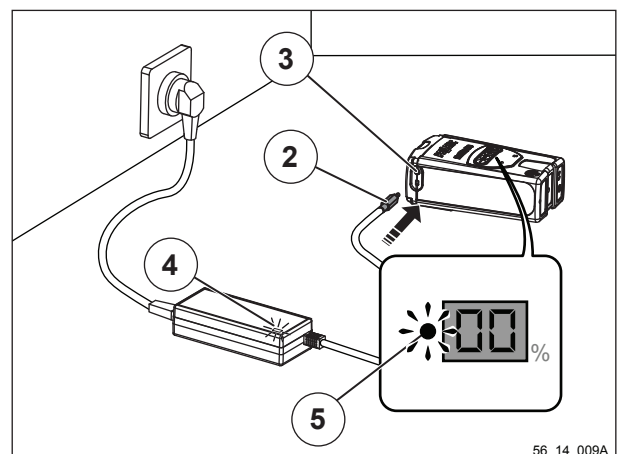

CHARGING THE BATTERY

E. When the gauge display (5) flashes, the battery is charging. Charging is complete when the message 99 is displayed steadily on the gauge (6) and the charger indicator (4) is on steady green.

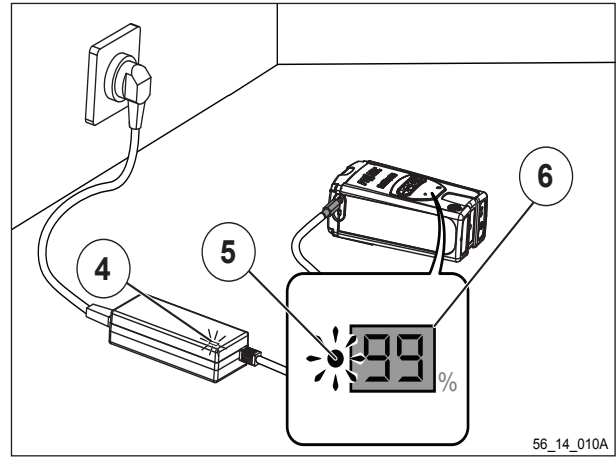

F. Once the battery is charged, disconnect the charging lead on the battery first (1), then the charger power connector (2).

NOTE

After a long storage period (new battery, winter storage etc.), when you disconnect the charger, the charge level indicator may display a value of less than 99%. This is a normal phenomenon which can reoccur for up to 5 charge cycles with normal use between each charge.

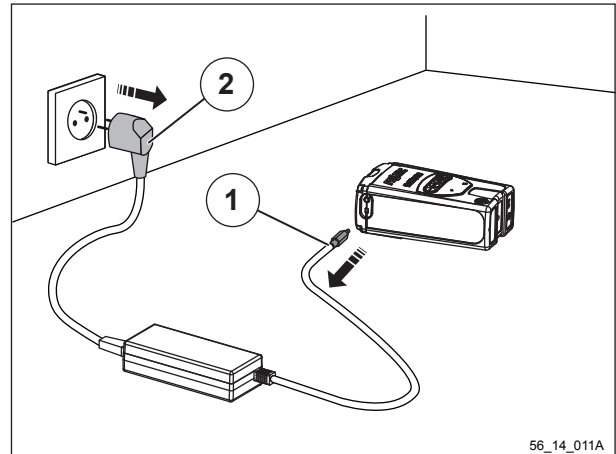

THE DISPLAY SHOWING REMAINING BATTERY CAPACITY

The battery is equipped with a gauge display which allows you to see the remaining capacity. The capacity is indicated in percentage.

- If the display shows 99, the battery is fully charged.
- If after a day's work, the display shows 55 there is no need to recharge the battery.
- If the display shows 00, or very close to it, it must be recharged at once.
- The battery gauge must be used like a fuel gauge on a car.

BATTERY REPLACEMENT

The battery must be replaced only by an approved distributor.

WHEN NOT IN USE

- Store the battery unit and charger away from heat, dust and damp, and check the LED is actually off.
- Never store the battery at an ambient temperature of more than +25 °C.
- **In order to conserve a long battery life and prevent deterioration, the battery must be charged when stored and recharged every 24 months if it is not used.**
- Never operate the switch while the shears are in storage.
- Battery life is guaranteed by storage in a dry place at a steady temperature between 0 and 25 °C.

- No combustible object must be placed within 1.5 metres of the battery.
- The charger is maintenance-free.
- Disconnect the charger before cleaning it. Clean the charger case using a damp cloth and a gentle detergent.
- If the battery is not used for 10 days, it discharges automatically to prepare for storage. During this phase it will become warm.

INCIDENTS

SUMMARY OF CHARGE INDICATOR AND BEEP MESSAGES	
NORMAL MESSAGES	
<i>USAGE</i>	
88 fixed	Battery charge level (0 to 99)
00 with 1 beep per minute	Battery empty, recharge immediately
00 flashing with 1 beep every 10 seconds	Stop using, recharge immediately
<i>CHARGING</i>	
88 flashing every 4 seconds	Battery charge level (0 to 99)
99 fixed	Charging complete
<i>STORAGE</i>	
88 flashing	Standby mode after 10 days of non-use (50 to 99)
DEGRADED MODE MESSAGES	
<i>USAGE</i>	
°C and 55 alternately	Stop the tool; the battery temperature is too high
Long beep and 1 short beep	Stop the tool: intensity is too high
Long beep and 4 short beeps	Stop the tool; the tool temperature is too high
<i>CHARGING</i>	
°C and 00 alternately	Charge interrupted: Battery temperature too low
°C and 45 alternately	Charge interrupted: Battery temperature too high
FAULT MESSAGES	
<i>USAGE</i>	
88 and beeps every 2 minutes for 24 hours	Voltage too low after 3 hours of non-use. Recharge battery immediately
<i>CHARGING</i>	
Pb and bA alternating and continuous beep	Battery problem
Pb and CH alternately	Charger problem

If your tool no longer works:

- 1– Turn off the battery (check that the LED is off).
- 2– Check the battery is charged, as shown on the gauge.
- 3– Check the lead is connected and the thumb-wheel tightened.
- 4– Turn on the battery (LED is on).
- 5– Press the trigger and the safety lock (depending on the tool).
- 6– If the tool does not work, return the complete equipment in its original packaging to a certified repair service.

NEVER ATTEMPT TO OPEN ONE OR MORE ELEMENTS OF THE "BATTERY" OR THE CHARGER UNIT (you risk damaging them and most importantly, you void the warranty).

«PELLENC S.A.» TERMS OF WARRANTY AND NON-RESPONSIBILITY CLAUSE

Warranty against latent defects

Apart from the commercial warranty foreseen under Article XX, Article 1641 of the Civil Code provides that "the seller is bound to a warranty on account of latent defects of the object sold which render it unfit for the use for which it was intended, or which would impair said use to the extent that the buyer would not have acquired it, or would only have given a lesser price for it, had he known of them".

Article 1648 of the Civil Code "The action resulting from latent defects must be brought by the purchaser within two years after the discovery of the defect. "

Legal warranty of conformity

Article L.211-4 of the Consumer Code "The seller must deliver goods in conformity with the contract and is liable for defects of conformity existing upon delivery. The seller is also liable for any lack of compliance resulting from the packaging, assembly or installation instructions, when these have been made its responsibility under the contract or have been produced under its responsibility

Article L.211-5 of the Consumer Code "To comply with the contract, the product must: 1) Be suitable for the purpose usually expected of similar goods and, where applicable: - Match the description given by the seller and possess the qualities that it has presented to the buyer as a sample or model; - The features that a buyer might reasonably expect given the public statements made by the seller, the producer or his representative, particularly in advertising or labelling; 2) or have the characteristics defined by mutual agreement by the parties or be suitable for any particular purpose for which the buyer made known to the seller and the latter accepted. "

Article L.211-12 of the Consumer Code "legal action resulting from lack of conformity lapses two years after delivery of the goods".

Commercial Warranty

General Information

In addition to legal warranties, client users benefit from the commercial warranty on PELLENC products covering the exchange and replacement of parts recognised out of use, caused by machining defects, assembly defects or material defects, whatever the cause.

The warranty forms an inseparable whole with the product sold by PELLENC.

Spare Parts

The commercial warranty also covers original PELLENC spare parts, excluding labour and to the exclusion of certain parts that fall within specific extended commercial warranties defined in the manual of each product provided at delivery.

Duration of the warranty

General Information

PELLENC products are guaranteed under the commercial warranty as from delivery to the customer for a period of two (2) years for products connected to a PELLENC battery, and for a period of one (1) year for other PELLENC products.

Spare Parts

PELLENC spare parts replaced under the product warranty are guaranteed under the commercial warranty as from delivery of the PELLENC product to the customer for a period of two (2) years for products connected to a PELLENC battery, and for a period of one (1) year for other PELLENC products.

In the case of products connected to a Pellenc battery, parts that are replaced in the under the product warranty after the 12th month of use, are covered for a period of one (1) year.

Warranty exclusions

Excluded from the commercial warranty are products that have been subject to abnormal use, or were used under conditions and for purposes other than those for which they were manufactured, especially in the case of non-compliance with conditions stipulated in the user manual.

It does not apply in case of shock, fall, neglect, lack of supervision or maintenance or in case of transformation of the product. Also excluded from the warranty are products that have been subject to tampering, alteration or modification by the client user.

Wear parts and/or consumables cannot be covered by the warranty.

Implementation of the commercial warranty

Product commissioning and commissioning declaration

The DISTRIBUTOR undertakes to complete the computer commissioning declaration form, no later than eight days after the delivery of the property to the user customer, in order to activate the latter on the www.pellenc.com website under "warranties and training" in the "extranet" menu, using the identifier previously provided to them by PELLENC.

Failing that, commissioning declaration will not be effective and implementation of the PELLENC commercial warranty will not occur. As a consequence thereof, the DISTRIBUTOR must ensure the financial burden of its intervention under the warranty without being able to pass on the cost to the client user.

The DISTRIBUTOR shall also undertake to complete the warranty card or the certificate of warranty and commissioning for self-propelled equipment provided with the product after having the client user sign and date it.

For the commissioning declaration to be effective, the DISTRIBUTOR undertakes to attach the warranty card present in each tool package or the warranty and commissioning certificate for self-propelled equipment, duly dated and signed by the client user, to the commissioning declaration to be made on the www.pellenc.com website.

Paid after-sales service

General Information

Malfunctions, breakdowns, breakages resulting from misuse, neglect or improper maintenance by the client user as well as malfunctions resulting from normal wear of the product are subject to the payment of after-sales service, even during the period of the legal and commercial warranty. After-sales service repairs that fall outside of the legal and commercial warranty also include maintenance, adjustments, diagnostics of all types, and cleaning without the present list being exhaustive.

Wear parts and consumables

Wear parts and consumables also fall within the after-sales service.

Spare Parts

Paid after-sales service also covers original PELLENC spare parts, excluding labour and outside the legal and commercial warranty period.

In case of replacement of original PELLENC spare parts in the context of after-sales service, said latter are covered by a warranty of one year as from the installation date.

Quality commitments

The DISTRIBUTOR undertakes to comply with the following quality commitments:

Inform the client user in writing of the cost of delivery at the time of purchase of the tool, if the product must be delivered.

Inform the client user in writing of the cost of commissioning, at the time of purchase of the tool, if the commissioning service must be paid for

Inform the client user in writing of the cost of user training on self-propelled harvesting machines, at the time of purchase of the tool, if the service must be paid for

Inform the client user of the precautions to be taken, safety instructions and risks related to the use of PELLENC products, as listed in each user manual and more generally provide information, advice and warnings related to the use PELLENC products.

Give the user manuals to the client user at the time of delivery of the goods or during the scheduled commissioning.

Present the features of the tool during commissioning.

List the personal protective equipment (PPE) required when using the product concerned at the time of commissioning.

SPECIAL WARRANTY CONDITIONS

PELLENC s.a. guarantees its motor for a period of **2 YEARS** from the date of delivery.

PELLENC s.a. guarantees the battery for a period of **2 YEARS** from the date of delivery, on the condition that:

- the number of recharging operations does not exceed 100 per year,
- the battery charging capacity has not exceeded 1 000 000 mAh since it was put into service,
- the battery is used at a temperature of between -5 °C and +35 °C (+23 °F and +95 °F),
- the battery is charged at a temperature of between +10 °C and +25 °C (+50 °F and +77 °F),
- the battery has not been heavily discharged,
- the average consumption does not exceed 350 mA.



NEVER ATTEMPT TO OPEN THE PRUNING SHEARS OR «BATTERY» PACK OR THE WARRANTY WILL BE NULLIFIED. CONTACT AN APPROVED REPAIR CENTER.

PATENTED EQUIPMENT

• **PELLENC** reserves the right to make all design and manufacturing changes deemed necessary in order to enhance **PERFECTION**.

Roger PELLENC

Chief Executive Officer



"EC" DECLARATION OF CONFORMITY

MACHINES DIRECTIVE 2006/42/CE

(ONLY CONCERNS EUROPE)

MANUFACTURER	PELLENC S.A.
ADDRESS	QUARTIER NOTRE-DAME ROUTE DE CAVAILLON - B.P. 47 84122 PERTUIS CEDEX (FRANCE)
PERSON/ENTITY AUTHORISED TO COMPILE THE TECHNICAL DOSSIER	PELLENC S.A.
ADDRESS	QUARTIER NOTRE-DAME ROUTE DE CAVAILLON - B.P. 47 84122 PERTUIS CEDEX (FRANCE)

WE HEREBY DECLARE THAT, FOR THE MACHINE HEREINAFTER REFERRED TO AS :

GENERIC DENOMINATION	ELECTRIC PRUNING SHEARS
FUNCTION	INTENDED FOR PRUNING
COMMERCIAL NAME	VINION
TYPE	- SELF-CONTAINED - ADAPTABLE
MODEL	VINION
SERIAL No.	26Q00001 - 26Q49999

COMPLIES WITH THE PERTINENT PROVISIONS OF THE MACHINES DIRECTIVE (2006/42/CE)

AND COMPLIES WITH THE PROVISIONS OF THE FOLLOWING OTHER EUROPEAN DIRECTIVES:

- ELECTROMAGNETIC COMPATIBILITY (2004/108/CE)
- LIMITATION OF THE USE OF HAZARDOUS SUBSTANCES IN ELECTRICAL AND ELECTRONIC EQUIPMENT (2011/65/EU)
- RECYCLING AND RECOVERY OF ELECTRICAL AND ELECTRONIC WASTE (2012/19/EU)

THE FOLLOWING HARMONIZED EUROPEAN STANDARDS WERE USED:

- EN 55014-1 : 2006 + A1 : 2009 + A2 : 2011
- EN 55014-2 : 1997 + A1 : 2001 + A2 : 2008
- EN 61000-3-2 : 2006 + A1 : 2009 + A2 : 2009
- EN 61000-3-3 : 2013
- EN 60745-1 : 2009 + A11 : 2010

CONCLUDED AT PERTUIS, DATED 01/12/2015
ROGER PELLENC
CHIEF EXECUTIVE OFFICER



“CE” STATEMENT OF CONFORMITY

MACHINES DIRECTIVE 2006/42/CE.

(ONLY CONCERNS EUROPE)

MANUFACTURER	PELLENC S.A.
ADDRESS	QUARTIER NOTRE-DAME ROUTE DE CAVAILLON - B.P. 47 84122 PERTUIS CEDEX (FRANCE)
PERSON/ENTITY AUTHORISED TO COMPILE THE TECHNICAL DOSSIER	PELLENC S.A.
ADDRESS	QUARTIER NOTRE-DAME ROUTE DE CAVAILLON - B.P. 47 84122 PERTUIS CEDEX (FRANCE)

WE HEREBY DECLARE THAT THE EQUIPMENT HEREINAFTER REFERRED TO AS:

GENERIC DENOMINATION	BATTERY
FUNCTION	INTENDED FOR POWERING HAND-HELD ELECTRIC PELLENC TOOLS
COMMERCIAL NAME	ULTRA LITHIUM BATTERY
TYPE	Li-Ion Battery
MODEL	150
SERIAL No.	26Q00001 - 26Q49999

COMPLIES WITH THE PROVISIONS OF THE FOLLOWING EUROPEAN DIRECTIVE:

- ELECTROMAGNETIC COMPATIBILITY 2004/108/CE

THE FOLLOWING HARMONISED EUROPEAN STANDARD HAS BEEN USED:

- NF EN 62133 (08/2013)

THE CHARGER COMPLIES WITH THE FOLLOWING STANDARDS :

- EN 60335-1 : 2012	- EN 55014-2 : 1997+A1 : 2001+A2 : 2008
- EN 60335-2-29 : 2004+A2 : 2010	- EN 61000-3-2 : 2006+A1 : 2009+A2 : 2009
- EN 62233 : 2008	- EN 61000-3-3 : 2013
- EN 55014-1 : 2006+A1 : 2009+A2 : 2011	- IEC / EN 61960 : 2011

CONCLUDED AT PERTUIS, DATED 01/12/2015

ROGER PELLENC
CHIEF EXECUTIVE OFFICER



