

ENG

Translation of the
original user guide



PELLENC POWER TOOL BATTERY OLIVION +

Operating instructions

56_131087-H
03/2020

**READ THE OPERATING INSTRUCTIONS
MANUAL CAREFULLY BEFORE USE**

TABLE OF CONTENTS

1. INTRODUCTION	4
2. SAFETY	5
2.1. SAFETY MEASURES ASSOCIATED WITH THE USE OF THE TOOL	5
2.2. SAFETY MEASURES ASSOCIATED WITH BATTERY USE	5
2.3. SAFETY MEASURES WHEN USING THE "PELLENC" CHARGER	6
2.4. STICKERS	7
3. DESCRIPTION AND TECHNICAL CHARACTERISTICS	8
3.1. TECHNICAL CHARACTERISTICS - BATTERY	8
3.2. TECHNICAL CHARACTERISTICS - CHARGER	8
3.3. DESCRIPTION	9
4. COMMISSIONING	10
4.1. FITTING THE BATTERY ON THE HARNESS	11
4.2. FITTING THE HARNESS	12
4.3. CHARGING THE BATTERY	15
5. UPKEEP	17
5.1. GAUGE DISPLAY	17
5.2. BATTERY REPLACEMENT	17
6. INCIDENTS AND TROUBLESHOOTING	18
6.1. SUMMARY OF GAUGE DISPLAY AND BEEP MESSAGES	18
7. STORAGE AND TRANSPORT	19
7.1. BATTERY STORAGE CONDITIONS	19
8. WARRANTIES	20
8.1. GENERAL WARRANTIES	20
8.1.1. STATUTORY WARRANTY	20
8.1.2. COMMERCIAL WARRANTYPELLENC	20
8.1.3. PAID AFTER-SALES SERVICE	21
9. COMPLIANCE STATEMENTS	23
9.1. "EC" DECLARATION OF CONFORMITY: OLIVION +	23

1. INTRODUCTION

Dear Customer,

Thank you for purchasing your PELENC Power Tool battery OLIVION +. Correctly used and maintained, this tool will give a satisfactory performance for many years.

Warning



Your device contains numerous recoverable or recyclable materials. Return it to your dealer or, failing this, to an approved servicing centre to be treated.



Comply with the regulations in force in your country as concerns environmental protection associated with your activity.

Warning



It is imperative that you read through the ENTIRE user's manual before using or servicing the tool. Always comply with the instructions and illustrations in the manual.

All through this user guide you will find advisory notes and information entitled: NOTE, IMPORTANT, ATTENTION and WARNING.

The points marked "NOTE" indicate additional information.

The points marked "IMPORTANT" warn the user of a potential risk to the equipment.

The points marked "ATTENTION" warn the user of a potentially hazardous situation which if not avoided leads to minor injuries.

The points marked "WARNING" warn the user of a potentially hazardous situation which if not avoided leads to serious injury or death.

The warning  indicates that damage resulting from failure to comply with the procedures and instructions is not covered by the warranty and the owner will be liable for any repair costs.

Safety indications are also given on the tool; they remind you of the safety precautions to be taken. Identify and read these indications before using the tool. Immediately replace any indications that may become partially illegible or deteriorated.

Refer to Section 2.4, "Stickers" for the location diagram of the safety stickers affixed to the tool.

No part of this manual may be reproduced without the written permission of the company PELENC. The illustrations given in this manual are for information purposes and are in no way contractual. The PELENC company reserves the right to make any modification or improvement to its products as deemed necessary without informing customers already in possession of a similar model. This manual forms an integral part of the tool and must accompany the tool if it changes hands.

2. SAFETY



Warning

Never carry out maintenance work on damaged battery packs. Service of battery packs should only be performed by the manufacturer or authorized service providers.

2.1. SAFETY MEASURES ASSOCIATED WITH THE USE OF THE TOOL

Note

Please refer to the instructions of the tool concerned.



Warning

Read all the safety measures and all the instructions. Retain all the safety measures and instructions for later reference.

This appliance is not intended for use by persons (including children) with reduced physical, sensory or mental capabilities, or lack of experience and knowledge, unless they have been given supervision or preliminary instructions by a person responsible for their safety.

2.2. SAFETY MEASURES ASSOCIATED WITH BATTERY USE

1. If not using the battery unit, store it away from other metal objects such as paper clips, coins, keys, nails, screws or other such small metal items that might form a connection between the two terminals. Creating a short-circuit between the battery terminals can lead to burns or cause a fire.
2. Keep the battery out of the reach of children and place it on a non-combustible support.
3. Do not interfere with its cooling cycle.
4. Do not use or leave the battery near a heat source ($> 60^{\circ}\text{C}$).
5. Do not leave the battery in direct, strong sunlight.
6. Do not expose the battery to microwaves or high pressure.
7. Do not immerse the battery in water.
8. The batteries must be charged in a dry, ventilated room at a temperature between 10°C and 25°C maximum, away from any moisture.
9. If the battery is not used for 10 days, the battery will automatically discharge until it reaches its storage charge rate, and then goes to sleep. It will heat up during this phase.
10. Over time, the capacity of your battery reduces. When it reaches half of its original battery-life operating time, it should be replaced.
11. The battery may lose 1 to 4 % of its capacity when exposed to a temperature higher than or equal to 55°C for one week.
12. The charging location must be equipped with a class D fire extinguisher (for metal fire) in good working order.
13. The standards in effect must be complied with when either shipping a complete tool or a battery.
 - A complete tool with a battery is a product that is classified as class 9, UN3481.
 - Battery alone: product that is classified as class 9, UN3480.
14. Use of a battery other than that provided by Pellenc SA is dangerous (risk of serious injury). If a different battery is used, Pellenc SA cannot be held responsible for any consequences.
15. The battery must be protected from any impact and must be positioned and secured appropriately during transportation.
16. In the case of suspicious smoke, place the battery outside the charging area or transportation vehicle as far away as possible from any inflammable material.
17. Never store a battery when its capacity is below 50 %. Recharge the battery before storage if the value is below 50%.

18. In inappropriate conditions, a liquid can flow batteries; avoid contact with it. In the event of accidental contact, rinse with water. In the event of contact with eyes, seek professional medical help. The liquid leaking from the batteries can cause irritations or burns.
19. Pellenc power tools must only be used with the battery units designed for the purpose. Use of other battery units can present a risk of injury and fire.
20. Only recharge using the charger indicated by the manufacturer. A charger adapted to one type of battery unit may present a fire risk if used with a different battery unit.
21. Do not use the battery for any purpose other than that initially envisaged (exclusively for use with Pellenc tools).
22. At the end of its life, the battery must be returned to the authorized distributor from whom it was purchased to be recycled in accordance with waste regulations.
23. Fragile case, contains an electronic board and lithium.

2.3. SAFETY MEASURES WHEN USING THE "PELENC" CHARGER

1. When in operation, the charger's temperature can reach 60°C. No flammable material must be within 1.5 metres of the charger and battery.
2. Place the charger out of children's reach and onto a non-combustible support.
3. Do not interfere with its cooling cycle.
4. The charger supplied with the battery is designed to recharge the battery. Do not charge non-rechargeable batteries.
5. The charging location must be equipped with a class D fire extinguisher (for metal fire) in good working order.
6. If the output cord is cut or damaged, bring the entire charger back to the authorised distributor where the tool was purchased.
7. Only recharge using the "PELENC" charger indicated by the manufacturer. A charger adapted to one type of battery unit may present a fire risk if used with a different battery unit.
8. This charger is designed to charge the batteries of Pellenc's lithium tools.
9. Do not use it for any other purposes.
10. Children must be supervised to ensure they do not play with the charger.
11. Verify that the cable cannot be folded and does not touch hot surfaces or sharp edges.
12. Ensure good ventilation during the charge.
13. Never cover the charger. This charger must not be used outdoors.
14. Make sure the power connector is not exposed to water.
15. Never charge a damaged battery.
16. The grid connection must comply with national electrical regulations.
17. Check the cable of the charger before using it. Never use the charger if the cable is damaged
18. When the battery is charging, place the charger on a non-flammable support, more than 1.5 m away from any flammable object.

2.4. STICKERS

OLIVION + battery

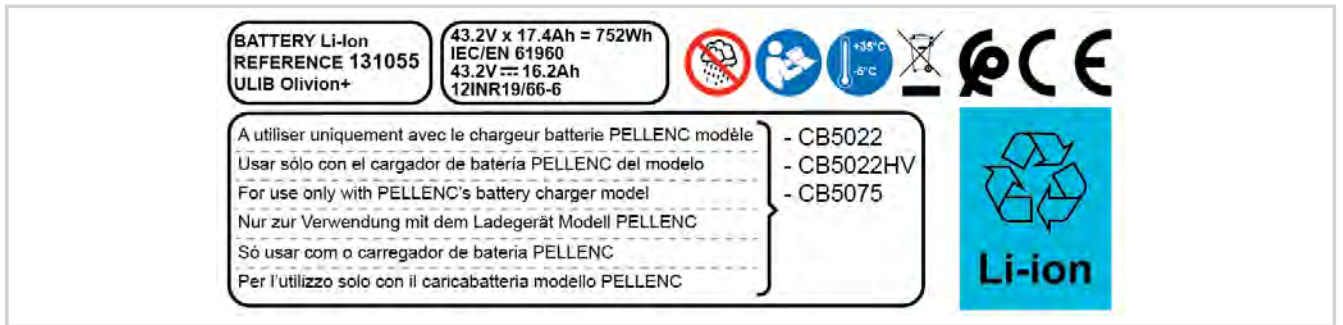

Do not expose to rain.



Read the user guide.



This equipment must be used at a temperature of between -5° and +35°C.



Lithium-ion battery.

At the end of its life, the battery must be returned to the authorized distributor from whom it was purchased to be recycled in accordance with waste regulations.



Tool compliant with Moroccan standards.



Tool compliant with EC standards.



Marking symbol for identifying the chemical characteristic of the battery during recycling.

3. DESCRIPTION AND TECHNICAL CHARACTERISTICS

3.1. TECHNICAL CHARACTERISTICS - BATTERY

Characteristics of OLIVION + battery	
Nominal\battery voltage	43.2 V ⁻⁻⁻
Type of battery	12 times 6 elements included in 1 pack
Battery capacity	17.4 Ah
Battery power	752 Wh
Battery life	Depending on the tool
Weight of the battery	4.9 kg
Weight of the carrying vest (comfort harness)	1.5 kg
Weight of the carrying vest (light harness)	0.83 kg
Operating frequency bands	13.56 MHz, receiver

3.2. TECHNICAL CHARACTERISTICS - CHARGER

	CB5022 Charger	Quick charger CB5075	CB5022HV charger
Commercial reference of the charger	57230	57011	57256
Voltage	100-240V ~ 50/60Hz 140W class II	100-240V ~ 50/60Hz 485W class I	100-240V ~ 50/60W 130W class II
Charging voltage	50.2 V dc		
Charging current	2.2A DC max.	7.6A dc max.	2.2A DC max.

Battery		OLIVION +
CB5022 Charger (2.2A)	70%	5 hrs. 30 min.
	100%	9 hrs
Quick Charger CB5075 (7.6 A)	70%	01:30
	100%	03:15
CB5022HV charger (2.2 A)	70%	5 hrs. 30 min.
	100%	9 hrs

Note

If after charging with the CB5075 charger the battery display indicates less than 95%, the next time the battery is charged it must be done with the original charger.

The sticker shown below is affixed to the CB5075 charger as a visual reminder of this warning.

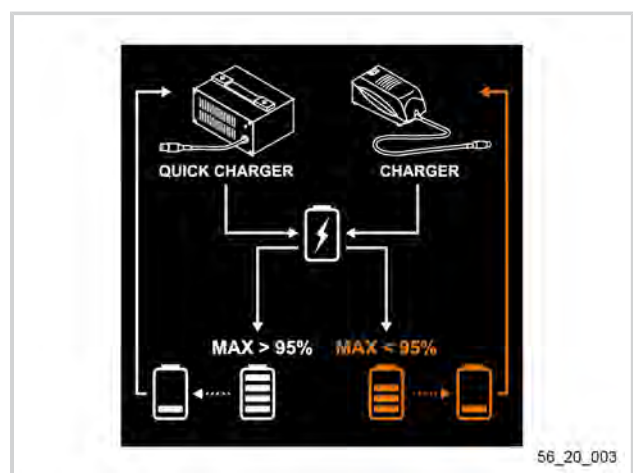

56_20_003

3.3. DESCRIPTION

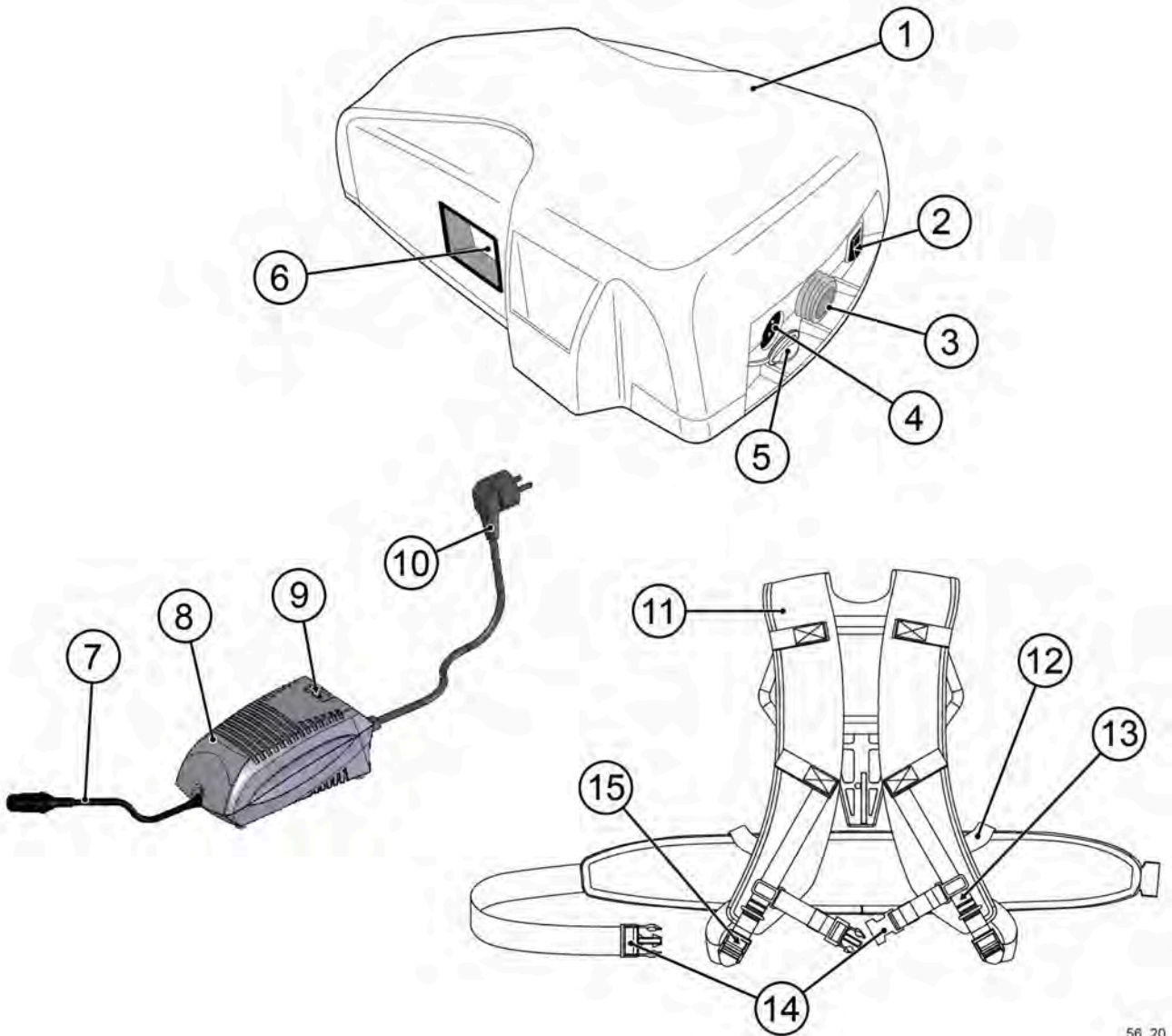

56_20_004

- | | |
|---------------------------------|-----------------------------|
| 1. Battery | 9. Charger indicator light |
| 2. ON/OFF switch | 10. Charger power connector |
| 3. Tool power cable connector | 11. Equipment carrier vest |
| 4. Charging connector (battery) | 12. Retaining strips |
| 5. Charge connector cap | 13. Straps |
| 6. Gauge display | 14. Tightening buckles |
| 7. Charging cord (charger) | 15. Chest adjustment loops |
| 8. Charger | |

4. COMMISSIONING

Important

The battery must be fully charged (100 %) before being using for the first time in the new season.

4.1. FITTING THE BATTERY ON THE HARNESS

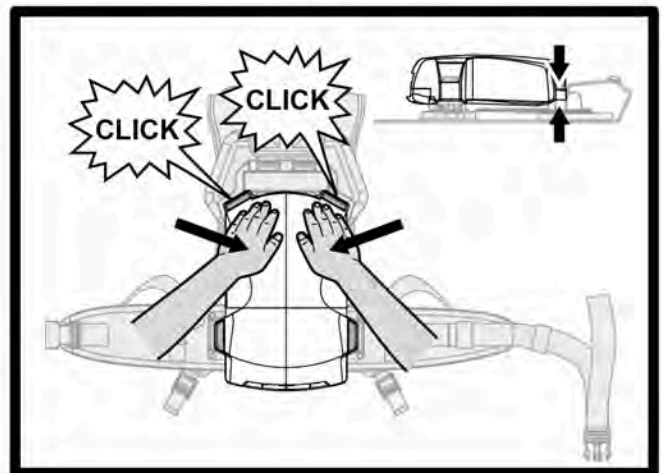
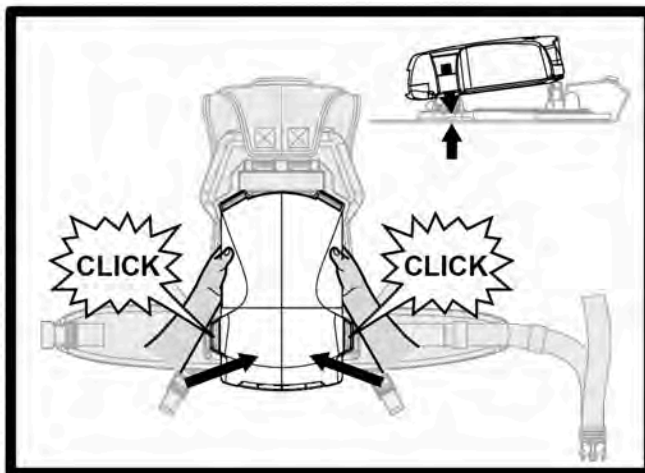
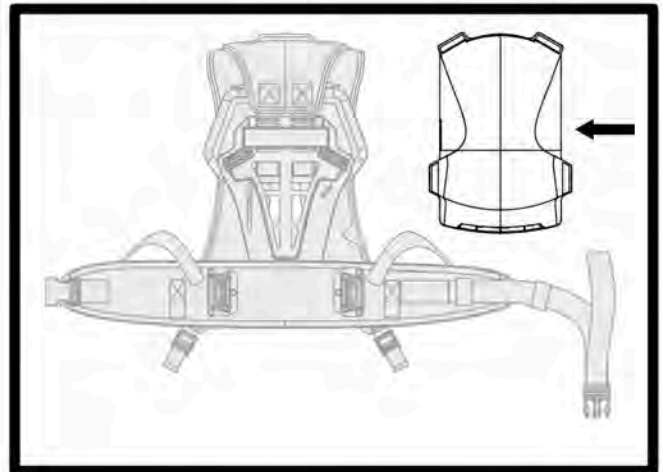
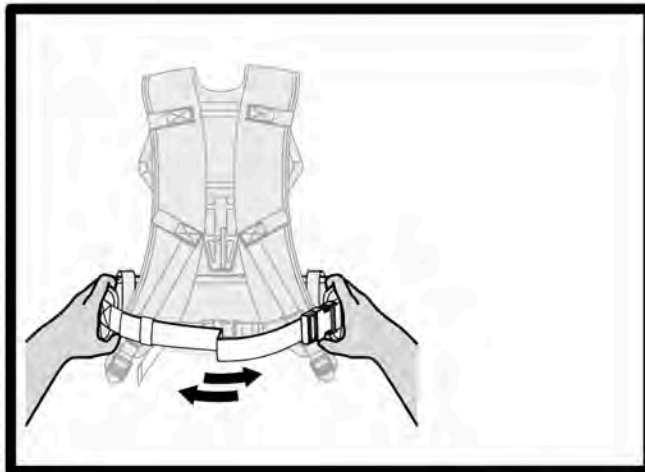
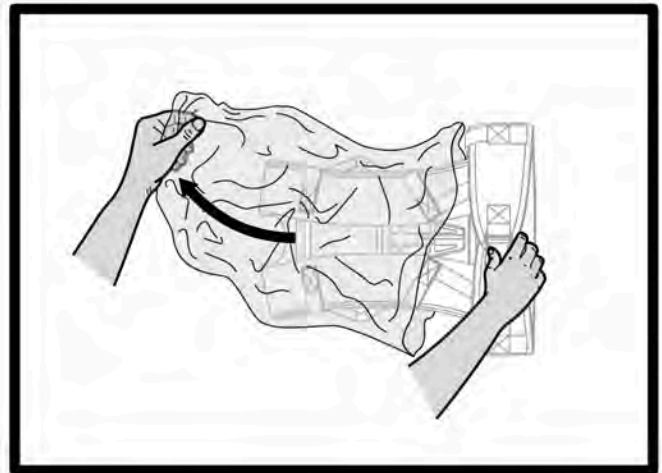
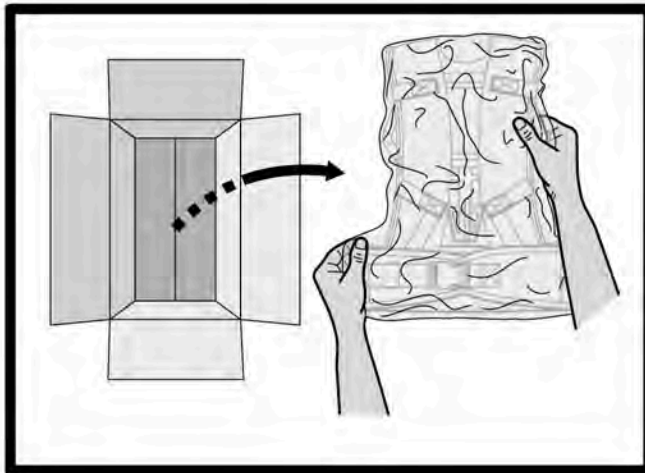

4.2. FITTING THE HARNESS

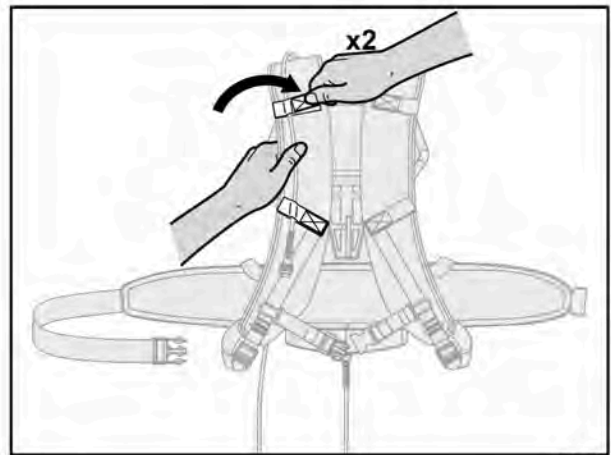
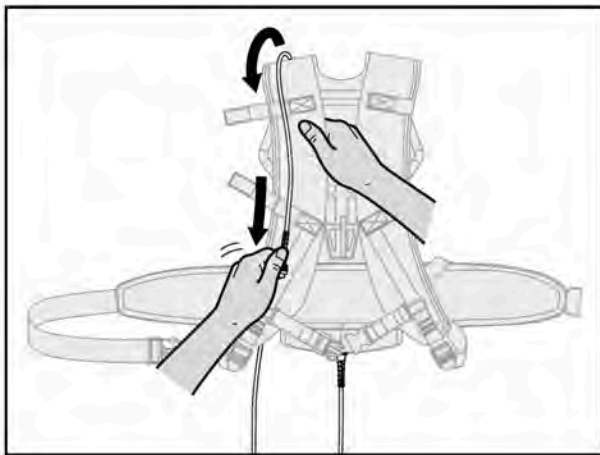
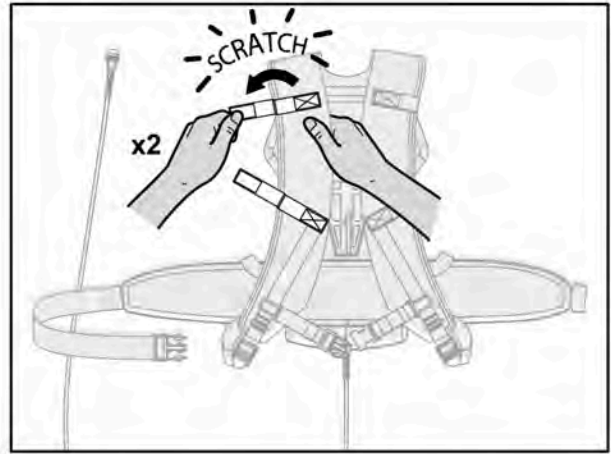
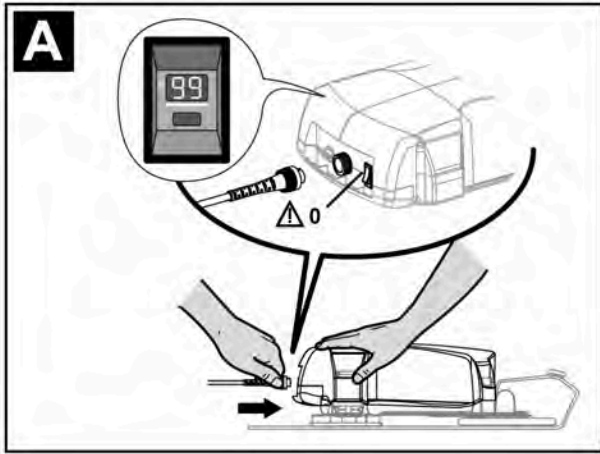

56_20_006

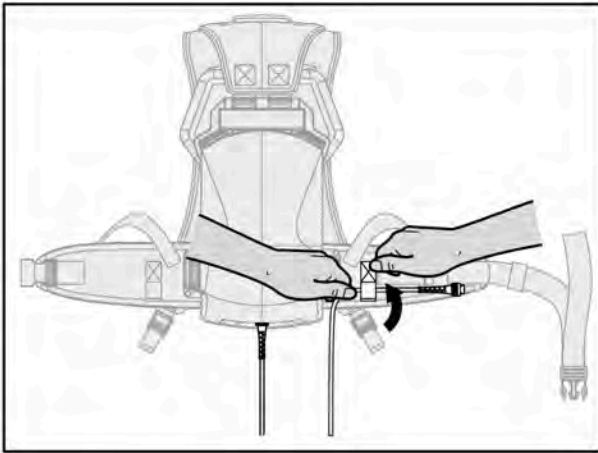
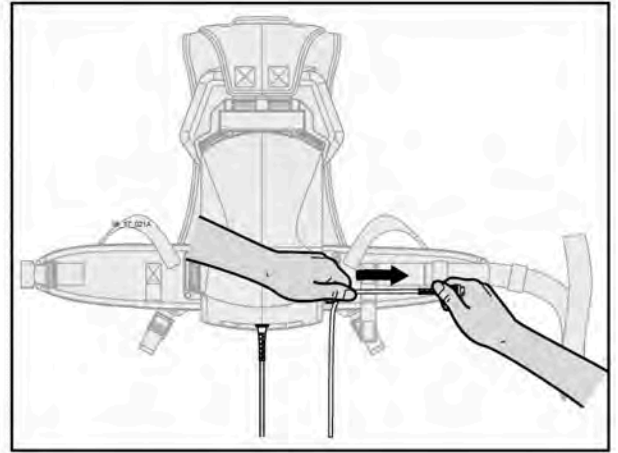
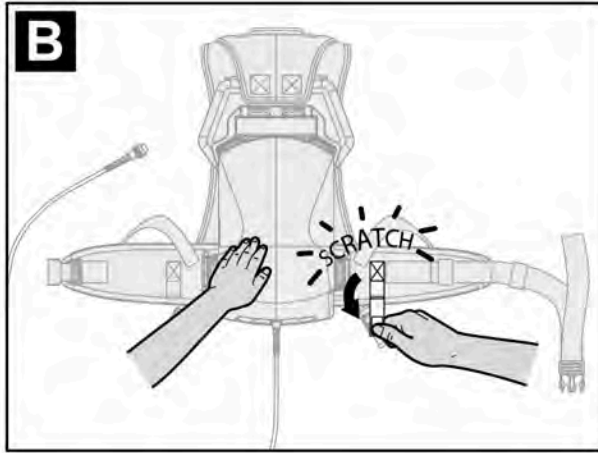

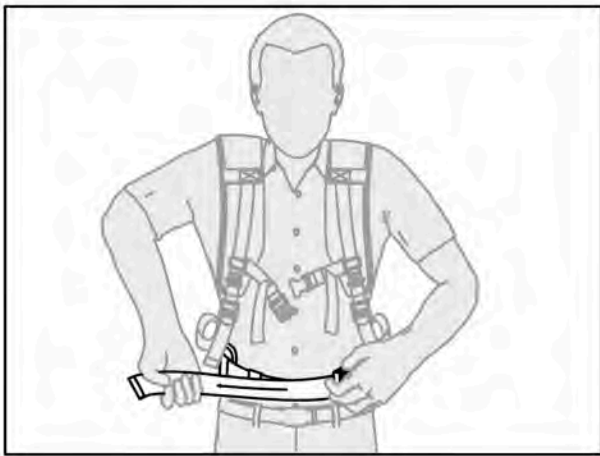
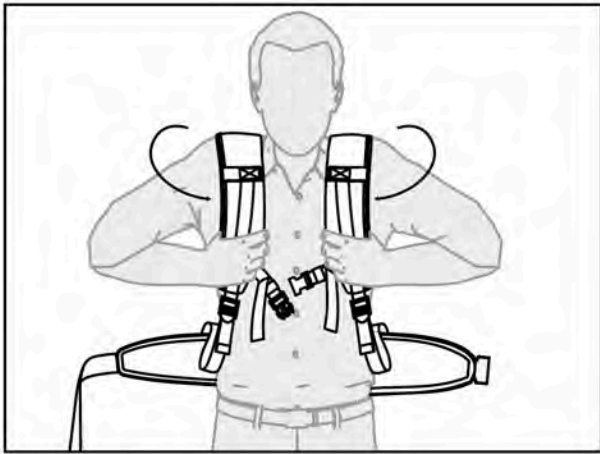

56_20_007

**Caution**

Protect your back by taking the necessary time to adjust your vest correctly.

Important

Ⓒ Never force the connectors.

Only use batteries with electric supply tool (3) connectors the same color as those present on the battery connector of the tool.

In any other event, please seek confirmation with your approved dealer of compatibility of the battery with the tools.

4.3. CHARGING THE BATTERY

1. Check that the battery switch (2) is turned to off (position '0').

Note

The battery must be fully charged (99 % on gauge display) before use the first time in the new season.

When the battery is discharged, the tool stops automatically, the battery gauge display (6) shows 0 % and the buzzer beeps intermittently (see Section 6, "Incidents and troubleshooting").

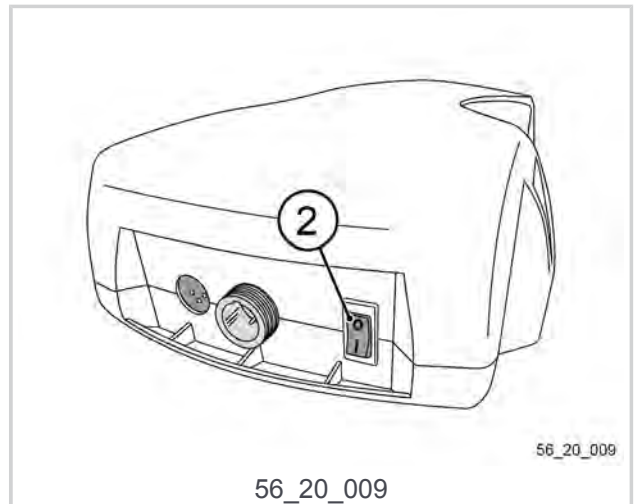

2. Place the charger and battery in a dry, ventilated and dust-free room at 10#25°C. Place the battery lying in a horizontal position.

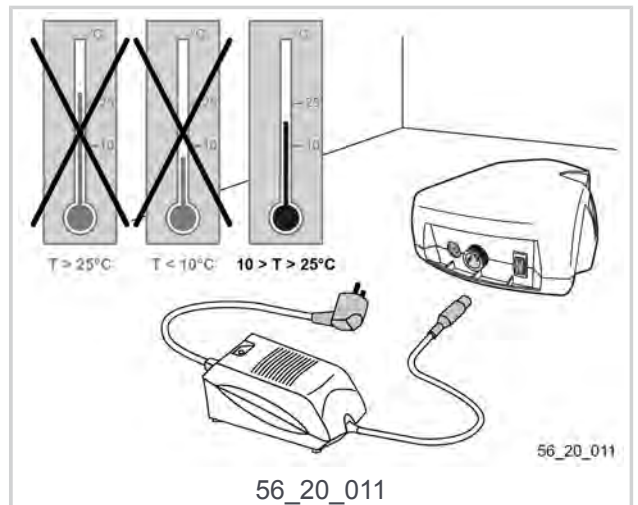

3. Connect the charger power connector (14) to the electrical power outlet. The charger LED lights up green.

Important

Ⓒ Before connecting the charger to the mains, check that your power system characteristics comply with the specifications given on the charger (see Section 3.2, "Technical characteristics - Charger").

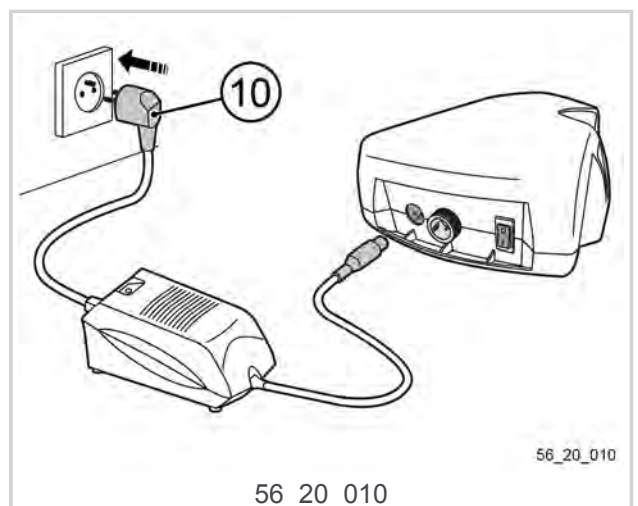

- Connect the charging cord (7) to the battery's charging connector (4).

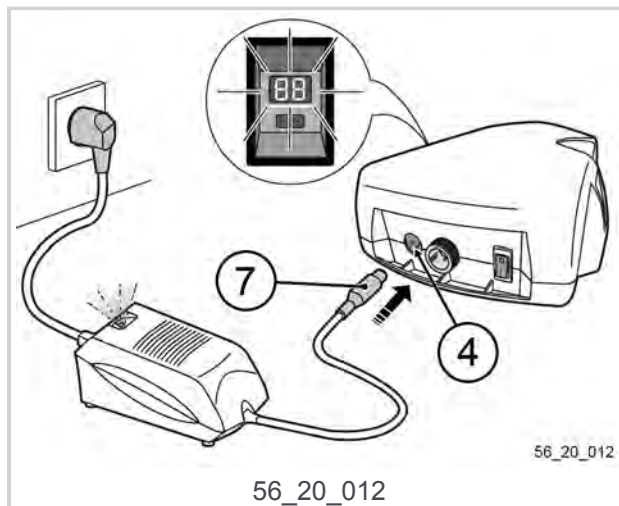

- When the gauge display (6) flashes, the battery is charging.

Note

Charging is complete when the message 99 appears steadily on the gauge display (6).

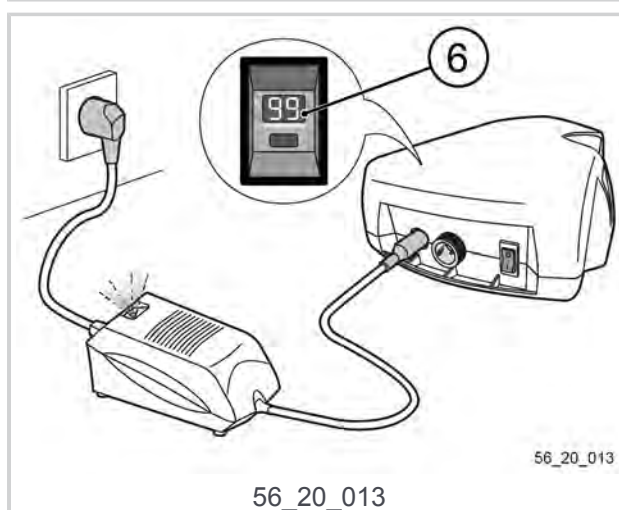

Once the battery is charged,

- disconnect the charging lead on the battery first (7),
- disconnect the charger power connector (10).

Note

After a long storage period (new battery, winter storage etc.), when you disconnect the charger, the charge level indicator (6) may display a value of less than 99%. This is a normal phenomenon which can reoccur for up to 5 charge cycles with normal use between each charge.

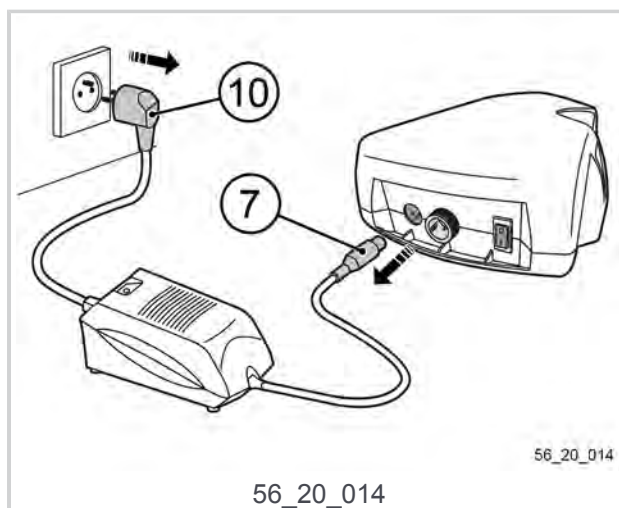

5. UPKEEP



Warning

Ⓒ Never service damaged battery packs. Service of battery packs should only be performed by the manufacturer or authorized service providers.

- Disconnect the charger before cleaning it. Clean the charger case using a damp cloth and a gentle detergent.

5.1. GAUGE DISPLAY

The battery is equipped with a gauge display (6) which allows you to see the remaining capacity. The capacity is expressed as a percentage.

- If the gauge display shows “99”, the battery is fully charged.
- If after a day's work the gauge display shows “55”, there is no need to recharge the battery before another day of work.
- If the display shows “00”, or very close to it, it must be recharged at once.
- The battery gauge must be used like a fuel gauge on a car.
- When the tool is being used, the indicator indicates the power consumption of the electric motor.

5.2. BATTERY REPLACEMENT



Warning

The battery must be replaced only by an approved distributor.

6. INCIDENTS AND TROUBLESHOOTING

6.1. SUMMARY OF GAUGE DISPLAY AND BEEP MESSAGES

Normal messages	
Use	
88 fixed	Battery charge level (0 to 99)
00 with 1 beep per minute	Battery empty, recharge immediately
00 flashing with 1 beep every 10 seconds	Stop using, recharge immediately
Charging	
88 flashing every 4 seconds	Battery charge level (0 to 99)
99 fixed	Charging complete
Storage	
88 flashing	Standby mode after 4 days of non-use (17 to 99)
Indicator off	Goes into storage after 7 days of non-use or voltage too low

Degraded mode messages	
Use	
°C and 55 alternately	Stop the tool; the battery temperature is too high
Long beep and 1 short beep	Stop the tool: intensity is too high
Long beep and 4 short beeps	Stop the tool; the tool temperature is too high
Charging	
°C and 00 alternately	Charge interrupted: Battery temperature too low
°C and 45 alternately	Charge interrupted: Battery temperature too high

Fault messages	
Using the tool	
88 and beeps every 2 minutes for 24 hours	Voltage too low after 3 hours of non-use. Recharge battery immediately
Charging	
Pb and bA alternating and continuous beep	Battery problem
Pb and CH alternately	Charger problem

If your tool no longer works:

1. Set the switch (2) to the off position «0».
2. Check the battery is charged, as shown on the gauge.
3. Check the lead is connected and the cable thumb-wheel tightened.
4. Set the switch (2) to the on position «1». Press the trigger and the safety lock (depending on the tool).
5. If the tool does not work, return the complete equipment in its original packaging to a certified repair service.



Warning

Ⓒ Never attempt to open one or more elements of the "battery" or the charger unit (you risk damaging them and most importantly, you void the warranty).

7. STORAGE AND TRANSPORT

7.1. BATTERY STORAGE CONDITIONS

- Store the battery unit and its charging device in a place away from any heat, dust or dampness, and ensure that the switch is on the "0" off position.
- Never store the battery in an ambient temperature of more than +45 °C.
- In order to conserve a long battery life and prevent deterioration, the battery must be charged when stored and recharged every 24 months if it is not used.
- Do not operate the switch while in storage.
- To ensure long battery life, the battery should be stored in a dry and warm place between 0 °C and 25 °C.
- No combustible object must be placed within 1.5 metres of the battery.
- The charger is maintenance-free.
- If the battery is not used for 10 days, the battery will automatically discharge until it reaches its storage charge rate, and then goes to sleep. Warming up occurs during this phase.

8. WARRANTIES

8.1. GENERAL WARRANTIES

8.1.1. STATUTORY WARRANTY

- 8.1.1.1. LATENT DEFECTS WARRANTY

Apart from the commercial warranty provided for under Article II, Article 1641 of the Civil Code provides that "the seller is bound to a warranty on account of latent defects of the object sold which render it unfit for the use for which it was intended, or which would impair said use to the extent that the buyer would not have acquired it, or would only have given a lesser price for it, had he known of them".

Article 1648 of the Civil Code "The action resulting from latent defects must be brought by the purchaser within two years after the discovery of the defect. "

- 8.1.1.2. LEGAL WARRANTY OF CONFORMITY

Article L.217-4 of the Consumer Code "The seller delivers goods in conformity with the contract and is liable for defects of conformity existing upon delivery.

The seller is also liable for any lack of compliance resulting from the packaging, assembly or installation instructions whenever its contractual liability is engaged in this regard or the latter are carried out under its responsibility

Article L.217-5 of the French Consumer Code "Goods are compliant with the contract":

1. Where they are fit for the purpose normally expected of similar goods and, where applicable:
 - If it matches the description given by the seller and possesses the qualities that were presented to the purchaser in the form of a sample or model;
 - If it possesses the qualities that a purchaser can reasonably expect given the public statements made by the seller, the producer or its representative, especially in advertising or labelling;
2. Or, if it has the characteristics defined by mutual agreement of the parties or is fit for any particular purpose that the buyer made known to the seller and that the latter accepted.

Article L.217-12 of the Consumer Code "legal action resulting from lack of conformity lapses two years after delivery of the goods".

8.1.2. COMMERCIAL WARRANTYPELENC

- 8.1.2.1. CONTENT

8.1.2.1.1. GENERAL INFORMATION

In addition to legal warranties, client users benefit from the commercial warranty on products PELENC covering the exchange and replacement of parts recognised as being out of order, due to machining defects, assembly defects or material defects, whatever the cause.

The warranty is fully integral to the product sold by PELENC.

8.1.2.1.2. SPARE PARTS

The commercial warranty also covers original PELENC spare parts, excluding labour and to the exclusion of certain parts of each product provided at delivery.

- 8.1.2.2. DURATION OF THE WARRANTY**8.1.2.2.1. GENERAL INFORMATION**

PELLENC Products are guaranteed under the commercial warranty as from delivery to the customer for a period of two (2) years for products connected to a PELLENC battery, and for a period of one (1) year for other PELLENC products.

8.1.2.2.2. SPARE PARTS

PELLENC Replacement parts replaced under the product warranty are guaranteed under the commercial warranty as from delivery of the PELLENC product to the customer user for a period of two (2) years for products connected to a PELLENC battery, and for a period of one (1) year for other PELLENC products.

In the case of products connected to a PELLENC battery, parts that are replaced under the product warranty after the 12th month of use, are covered for a period of one (1) year.

8.1.2.2.3. WARRANTY EXCLUSIONS

Excluded from the commercial warranty are products that have been subject to abnormal use, or were used under conditions and for purposes other than those for which they were manufactured, especially in the case of non-compliance with conditions stipulated in this user manual.

It does not apply in case of shock, fall, neglect, lack of supervision or maintenance or in case of transformation of the product. Also excluded from the warranty are products that have been subject to tampering, alteration or modification by the client user.

Wear parts and/or consumables cannot be covered by the warranty.

- 8.1.2.3. IMPLEMENTATION OF THE COMMERCIAL WARRANTY**8.1.2.3.1. PRODUCT COMMISSIONING AND COMMISSIONING DECLARATION**

The DISTRIBUTOR undertakes to complete the computer commissioning declaration form, no later than eight days after the delivery of the property to the user customer, in order to activate the latter on the www.pellenc.com website under "warranties and training" in the "extranet" menu, using the identifier previously provided to them by PELLENC.

Failing that, commissioning declaration will not be effective and implementation of the commercial warranty PELLENC will not occur. As a consequence thereof, the DISTRIBUTOR must ensure the financial burden of its intervention under the warranty without being able to pass on the cost to the client user.

The DISTRIBUTOR shall also undertake to complete the warranty card or the certificate of warranty and commissioning for self-propelled equipment provided with the product after having the client user sign and date it.

8.1.3. PAID AFTER-SALES SERVICE**- 8.1.3.1. GENERAL INFORMATION**

Malfunctions, breakdowns, breakages resulting from misuse, neglect or improper maintenance by the client user as well as malfunctions resulting from normal wear of the product are subject to the payment of after-sales service, even during the period of the legal and commercial warranty. After-sales service repairs that fall outside of the legal and commercial warranty also include maintenance, adjustments, diagnostics of all types, and cleaning without the present list being exhaustive.

- 8.1.3.2. WEAR PARTS AND CONSUMABLES

Wear parts and consumables also fall within the after-sales service.

- 8.1.3.3. SPARE PARTS

Paid after-sales service also covers original PELLENC spare parts, excluding labour and outside the legal and commercial warranty period.

In case of replacement of original PELLENC spare parts in the context of after-sales service, said latter are covered by a warranty of one year as from the installation date.

9. COMPLIANCE STATEMENTS

9.1. "EC" DECLARATION OF CONFORMITY: OLIVION +

MANUFACTURER	PELENC
ADDRESS	Quartier Notre-Dame - 84120 Pertuis (France)

ENTITY AUTHORIZED TO COMPILE THE TECHNICAL FILE	PELENC
ADDRESS	Quartier Notre-Dame - 84120 Pertuis (France)

We hereby declare that the machine referred to below as:

GENERIC DENOMINATION	BATTERY
FUNCTION	Designed to supply PELENC's harvesting machines
COMMERCIAL NAME	ULTRA LITHIUM BATTERY OLIVION +
TYPE	Li-ion battery
MODEL	OLIVION +
SERIAL No.	56U00001 - 56U49999 56V00001 - 56V49999 56W00001 - 56W49999

Complies with the provisions of the following European directives:

- 2014/30/EU EMC Directive
- 2011/65/EU ROHS Directive
- 1907/2006 REACH Regulation
- 2006/66/EC Directive relative to batteries and accumulators

The battery complies with the following standards:

- EN 62133: 2013

SIGNED IN PERTUIS, DATED 02/03/2020
JEAN-MARC GIALIS
CEO



PELLENC

   www.pellenc.com

PELLENC
Quartier Notre Dame - 84120 Pertuis (France)

